



Other languages in digital format can be downloaded at [www.ostberg.com](http://www.ostberg.com)

The manufacturer cannot be held liable for injury and damage to people or property that are caused by incorrect installation, start up and/or incorrect use of the unit and/or failure to follow the processes and instructions that are set out in the manual. For safety reasons it is essential to follow the instructions in the manual. The warranty will be immediately invalidated in the event of injury that is caused by failure to follow the instructions. Installation and commissioning must be performed by a professional in order for the warranty to apply.

### Shortcuts:

- **Log in Installation menu:** Enter code 1991.
- **Log in Service menu:** Enter code 1199.
- **Bluetooth pairing code:** 123456
- **Download the latest firmware version:** [Firmware.](#)
- **Download complete Modbus register:** [Modbus.](#)

#### FIRMWARE

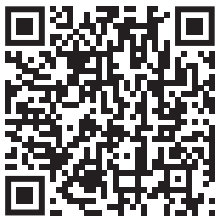

#### MODBUS



- **Download the app:** [IQ Control App.](#)

#### APPLE



#### GOOGLE



- **Download wiring diagrams via the links below**

#### HERU S

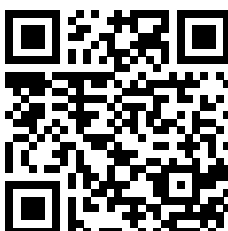

#### HERU T

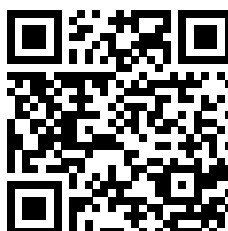

Information about the products at [www.ostberg.com](http://www.ostberg.com)

---

<b>1</b>	<b>PRODUCT OVERVIEW AND USE</b>	<b>4</b>
1.1	Product description	4
1.2	Control functions	5
1.2.1	Regulating the temperature	5
1.2.2	Fan capacity	5
<b>2</b>	<b>SAFETY</b>	<b>6</b>
2.1	Warnings	6
2.2	General safety	6
2.3	Declaration of conformity	8
<b>3</b>	<b>WARRANTY</b>	<b>10</b>
3.1	Extent of the warranty	10
3.2	General limitations in the warranty	10
3.3	Limitations in the warranty	10
3.4	Service conditions during the warranty period	11
3.5	Corrective measures in the event of detected faults	11
<b>4</b>	<b>OPERATION</b>	<b>12</b>
4.1	Installing the IQ Control App	12
4.2	Pairing units	13
4.3	Entering the basic settings	13
4.4	IQ Control App	14
4.4.1	Home screen	14
4.5	Temperature regulation	14
4.6	Boost – used for temporarily increased ventilation needs	15
4.6.1	Boosting the unit	15
4.6.2	Change operating time for boost	15
4.7	Overpressure – is used to facilitate the lighting of a fireplace	15
4.7.1	Activate overpressure	15
4.7.2	Change operating time and compensation for overpressure function	15
4.8	Activate Away mode	16
4.9	Scheduling	16
4.10	Activate night cooling	17
4.11	Activate Heater	17
4.12	Turn the unit off and on	18
4.13	Use the Alarm menu	18
4.14	Change settings	18
4.15	Update firmware in the ventilation unit	18
<b>5</b>	<b>MAINTENANCE</b>	<b>19</b>
5.1	Maintenance schedule	19
5.2	Maintenance	19
5.2.1	Maintenance every six months	19
5.2.2	Maintenance every year	19
5.3	Preparations	20
5.4	Open doors and lid	20
5.5	Remove filters and fans	21
5.6	Accessories and spare parts	22
<b>6</b>	<b>TECHNICAL DATA</b>	<b>23</b>
<b>7</b>	<b>TROUBLESHOOTING</b>	<b>24</b>
7.1	Alarm	24
7.2	Other malfunctions	25
7.3	Troubleshooting chart	26
	<b>APPENDIX 1 IQ CONTROL APP – SETUP WIZARD</b>	<b>28</b>

---

# 1 Product overview and use

## 1.1 Product description

The energy recovery units HERU S and HERU T are designed for supply air and exhaust air ventilation with cooling and heat recovery.

The unit

- is equipped with an inbuilt electric after heater.
- is supplied with ePM1 filters.
- is easily controlled using the IQ Control App.
- has as a accessory, a wireless display for operation and monitoring of the unit.
- has Modbus communication via RS485.

HERU S and HERU T can be used in the home, in the office, in apartments etc., where there is a need for:

- high temperature efficiency
- high temperature efficiency
- energy saving
- low sound levels
- safe operation
- high reliability

## 1.2 Control functions

### 1.2.1 Regulating the temperature

The air temperature can be regulated for either constant supply, room or exhaust air temperature.

- To regulate room temperature, a sensor must be positioned in the room (accessory).
- The unit's inbuilt exhaust air sensor is used for exhaust air temperature.
- If the selected mode does not maintain the desired temperature, regulation moves to the next mode.

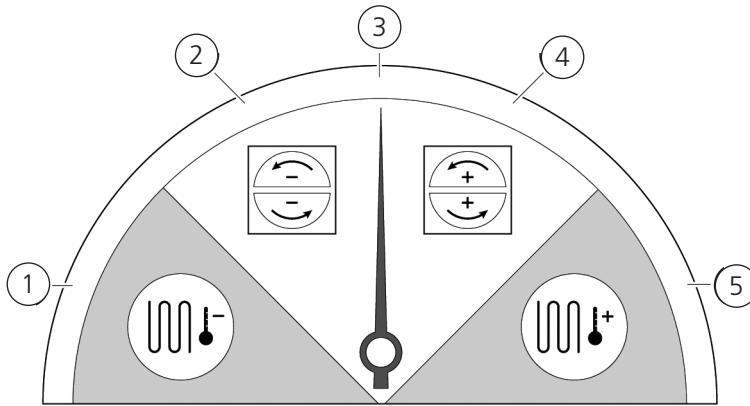

**There are 5 modes for regulating temperature:**

**1. Cooling recovery and/or after cooling:**

In climate conditions where the rotating heat exchanger is not adequate to achieve the desired supply air temperature, the unit also controls a cooling battery (e.g. via geothermal heating) when the cooling recovery from the rotor is not sufficient to maintain the desired temperature. This mode can also be used if this is not possible using cooling recovery.

**2. Cooling recovery:**

The rotating heat exchanger starts when cooling recovery is possible in order to maintain a lower supply air temperature.

**3. Outdoor temperature = desired temperature:**

When the outdoor temperature is the same as the desired supply air temperature, the rotating heat exchanger stops.

**4. Heat recovery:**

The rotating heat exchanger starts to recover the warm indoor temperature.

**5. Heat recovery and/or after heat:**

In climate conditions where the rotating heat exchanger is not adequate to achieve the desired supply air temperature, the unit can also control either the inbuilt electric after heater or a heating battery.

### 1.2.2 Fan capacity

Minimum airflow is set to suit the minimum requirement for ventilation. The basic setting is set to essential airflow for the ventilation. Maximum airflow is the airflow that is set to obtain higher airflow, if needed.

The airflow (the fan speed) can be controlled by a program planner, which can be programmed with specific times when the fan will switch from one speed to another.

Using the program planners, different fan speeds can be programmed, such as lowest, highest or standard fan speed. The fan speed can also be regulated by a carbon dioxide (CO<sub>2</sub>) and humidity (RH) sensor so that the unit increases the airflow as much as required in order to maintain the value once the value is exceeded.

“Night cooling” is a function that means you can use the cold outdoor temperature at night to cool the indoor temperature. The fan speed is boosted when the difference between outdoor and exhaust air temperature lies within the programmed limits.

## 2 Safety

### 2.1 Warnings

**WARNING**

A warning states a risk of personal injury.

**CAUTION**

Caution states a risk of damage to equipment.

### 2.2 General safety

**WARNING**

In accordance with IEC 60335-2-7.12, this apparatus is not intended to be used by people (including children) who have physical, sensory or psychological impairment, or lack of experience and knowledge, unless they have received guidance and instruction on how to use the apparatus by a person who is responsible for their safety. Children must be supervised to ensure that they do not play with the apparatus.

**WARNING**

Watch out for sharp edges and corners on the HERU unit.

**WARNING**

Protective gloves must be worn due to the risk of cuts or injury.

**WARNING**

The unit's ducts must be connected, and doors and/or cover closed and locked before the unit is started in order to avoid the risk of personal injury from rotating parts.

**WARNING**

The power supply to the HERU unit must be disconnected for all service and maintenance.

**WARNING**

The electric after heater may remain hot even after the power has been disconnected for service and maintenance.

**WARNING**

All changes or additions of electrical components must be performed by a qualified electrician.

**WARNING**

Breathing protection and protective clothing must be used due to the risk of breathing in and spreading dust when handling used air filters.

**CAUTION**

Always turn off the unit with the IQ Control App or the Display (accessories) before cutting the power.

**CAUTION**

The safety switch must not be used for normal starting and stopping of the unit. Use the IQ Control App.

**CAUTION**

The safety switch must be set to mode 0 after the unit has been turned off before service can be started.

**CAUTION**

Do not connect an exhaust air type tumble dryer or drying cabinet to the system due to the high air humidity.

**CAUTION**

The unit must not be turned off for longer periods unless the duct connections for outdoor air and extract air are re-plugged due to the risk of condensation and freezing.

**CAUTION**

In the event of any interruption in power, the settings will be saved. Date and Time are saved for 24 hours. In longer interruptions, Date and Time must be reset.

## 2.3 Declaration of conformity



### EU DECLARATION OF CONFORMITY

We hereby confirm that our products comply with the requirements in the following EU-directives and harmonised standards and regulations.

**Manufacturer:** H. ÖSTBERG AB  
 Industrigatan 2  
 SE-774 35 Avesta, Sweden  
 Tel No +46 226 860 00  
 Fax No +46 226 860 05  
<http://www.ostberg.com>  
[info@ostberg.com](mailto:info@ostberg.com)  
 VAT No SE556301220101



**Products:** Bidirectional ventilation unit RVU: HERU® 95 T EC, HERU® 100 T EC, HERU® 160 T EC, HERU® 200 T EC, HERU® 300 T EC, HERU® 100 S EC, HERU® 160 S EC, HERU® 200 S EC, HERU® 300 S EC, HERU® 70 K EC, HERU® 50 LP EC, HERU® 90 LP EC, HERU® 180 S EC 2, HERU® 250 T EC, HERU® 130 S EC, HERU® 250 S EC  
 Bidirectional ventilation unit NRVU: HERU® 400 T EC, HERU® 600 T EC, HERU® 800 T EC, HERU®, 1200 T EC, HERU® 400 S EC, HERU® 600 S EC, HERU® 800 S EC, HERU® 1200 S EC, HERU® Select

This EU declaration is applicable for products including our accessories for mounting and installation only if the installation is made in accordance with the enclosed installation instructions and that the product has not been modified.

#### Radio Equipment Directive (RED) 2014/53/EU

Harmonised standards:

- EN 300 220-2:2018 V3.1.1
- EN 303 446-1:2019 (EN 55014-1:2017, A11, EN 55014-2:2015, EN IEC 61000-3-2:2019, EN 61000-3-3:2013, A1)
- EN 301 489-3:2019

#### Machinery Directive (MD) 2006/42/EC

Harmonised standards:

- EN ISO 12100:2010
- EN ISO 13857:2019
- EN 60204-1:2018
- EN 60335-1:2012, AC 1, A 13 R1, A 11, A 12, A 13, A 1, A 14, A2, A15
- EN 60335-2-40:2003, A13, A2, A12, A1, A11, C1, C2
- EN 60335-2-30:2010, A11, A1, A12

#### Ecodesign Directive 2009/125/EC

Harmonised regulation:

- 1253/2014 Ecodesign requirements for ventilation units
- 1254/2014 Energy labeling of residential ventilation units

Standards:

- RVU: SS-EN 13141-7:2021 or NRVU: SS-EN 13053:2019

#### RoHS Directive 2011/65/EU

Harmonised standards:

- EN IEC 63000:2018

Avesta 2022-04-25

Mikael Östberg  
 Product Manager

This document is digitally signed.





## GB DECLARATION OF CONFORMITY

We hereby confirm that our products comply with the requirements in the following UK legislations and designated standards.

**Manufacturer:** H. ÖSTBERG AB  
 Industrigatan 2  
 SE-774 35 Avesta, Sweden  
 Tel No +46 226 860 00  
 Fax No +46 226 860 05  
<http://www.ostberg.com>  
[info@ostberg.com](mailto:info@ostberg.com)  
 VAT No SE556301220101



**Products:** Bidirectional ventilation unit RVU: HERU® 95 T EC, HERU® 100 T EC, HERU® 160 T EC, HERU® 200 T EC, HERU® 300 T EC, HERU® 100 S EC, HERU® 160 S EC, HERU® 200 S EC, HERU® 300 S EC, HERU® 70 K EC, HERU® 50 LP EC, HERU® 90 LP EC, HERU® 180 S EC 2, HERU® 250 T EC, HERU® 130 S EC, HERU® 250 S EC  
Bidirectional ventilation unit NRVU: HERU® 400 T EC, HERU® 600 T EC, HERU® 800 T EC, HERU®, 1200 T EC, HERU® 400 S EC, HERU® 600 S EC, HERU® 800 S EC, HERU® 1200 S EC, HERU® Select

This GB declaration is applicable for products including our accessories for mounting and installation only if the installation is made in accordance with the enclosed installation instructions and that the product has not been modified.

### **Radio Equipment Regulations 2017, S.I. 2017 No. 1206**

#### Designated standards:

- EN 300 220-2:2018 V3.1.1
- EN 303 446-1:2019 (EN 55014-1:2017, A11, EN 55014-2:2015, EN IEC 61000-3-2:2019, EN 61000-3-3:2013, A1)
- EN 301 489-3:2019

### **The Supply of Machinery (Safety) Regulations 2008, S.I. 2008 No. 1597**

#### Designated standards:

- EN ISO 12100:2010
- EN ISO 13857:2019
- EN 60204-1:2018
- EN 60335-1:2012, AC 1, A 13 R1, A 11, A 12, A 13, A 1, A 14, A2, A15
- EN 60335-2-40:2003, A13/AC, A2, A12, A1, A11, AC1, AC2

#### Standard:

- EN 60335-2-30:2010, A11, A1, A12

### **The Ecodesign for Energy-Related Products and Energy Information (Amendment) (EU Exit) Regulations 2019, S.I. 2019 No. 539**

#### Retained regulation:

- 1253/2014 Ecodesign requirements for ventilation units
- 1254/2014 Energy labeling of residential ventilation units

#### Standards:

- RVU: SS-EN 13141-7:2010 or NRVU: SS-EN 13053:2019

### **Restriction of the Use of Certain Hazardous Substances in Electrical and Electronic Equipment Regulations 2012, S.I. 2012 No. 3032**

#### Designated standards:

- EN IEC 63000:2018

Avesta 2024-05-21

Mikael Östberg  
 Product Manager

This document is digitally signed.

## 3 Warranty

The warranty's validity according to the purchase agreement is calculated from the day of purchase.

### 3.1 Extent of the warranty

The warranty covers faults that occur during the warranty period that have been notified to the dealer or which have been verified by H.Östberg AB (underwriter) or the warranty provider's representative. Faults are defects in manufacture and materials as well secondary failures that occur due to these.

The above faults must be remedied so that the product is operational.

### 3.2 General limitations in the warranty

The warranty provider's liability is limited according to these warranty conditions and the warranty does not cover injury or damage to people or property. Verbal promises that are made in addition to the warranty agreement are not binding on the warranty provider.

### 3.3 Limitations in the warranty

The warranty applies on condition that the product is used in the normal manner or under equivalent circumstances and that the user instructions are followed.

The warranty does not cover faults that are caused by:

- Transport of the product.
- Unintended use or overloading of the product.
- Failure on the part of the user to follow the instructions regarding installation, use, maintenance and care.
- Incorrect installation or incorrect positioning of the product.
- Conditions that are not the responsibility of the warranty provider, e.g. excessive variations in voltage, lightning strike, fire and other accidents.
- Repairs, maintenance and changes that are performed by unauthorised parties.

The warranty does not cover:

- Faults that do not affect operation, for example scratches to the surfaces.
- Parts that are exposed to greater risk of fault than normal due to handling or normal wear and tear, for example lamps, glass, ceramics, paper or plastic parts, filters and fuses.
- Settings, information on use, care, service or cleaning that are typically described in the user instructions, or damage that is caused by the user failing to observe warnings or installation instructions, or inspection of such.

The warranty provider is only responsible for the operation if approved accessories are used. The warranty does not cover product faults that are caused by other manufacturers' accessories or equipment.

The unit's current settings must be recorded in the installation and assembly instructions at installation in order to avoid costs in the event of fault. The warranty provider is not responsible for costs such as adjustment costs when changing fans and mainboards in the unit.

### **3.4 Service conditions during the warranty period**

The conditions apply according to the agreement with the local dealer.

### **3.5 Corrective measures in the event of detected faults**

If a fault is detected, the customer must notify this to the dealer.

Shipping damage must be notified to the shipping agent upon delivery. State which product applies (part and serial number as per the name plate) and describe the fault and how this has occurred as accurately as possible.

In order for warranty repair to be performed, the customer must demonstrate that the warranty is valid by presenting a purchase receipt. Once the warranty period has expired, claims that were not made in writing before expiry of the warranty period will not be valid. In other regards, this shall occur in accordance with the sales conditions.

## 4 Operation

For information on active view in the IQ Control App, press the **i**-button in the App's status bar.



### WARNING

The unit's duct connections must be duct connected, and doors/cover closed and locked before the unit is started in order to avoid the risk of personal injury from rotating parts.



### CAUTION

The unit must be run constantly and only be stopped for maintenance.



### CAUTION

The safety switch must not be used for normal starting and stopping of the unit. Use the IQ Control App.



### CAUTION

In the event of interruption in power, the settings will be stored. Date and Time are saved for 24 hours. After that, Date and Time must be reset. Make sure the unit is started up.

The airflow is regulated in the mode using the IQ Control App. Normal mode is the preset base mode.

Accessible modes:

- Away**                      Reduced air flow, can be used when no one is home.
- Normal**                    Adjusted at installation, must not be changed.
- Boost**                      A higher airflow than normal, medium/max can be selected. This alternative should be used when there is need for a higher airflow, for example when cooking food, drying laundry or taking a sauna.
- Overpressure**            Pressure compensation in the event of supplementary heating, for example, when using an open cooker or stove.

Certain settings are protected by a code so they cannot be changed unintentionally.

### NOTE!

If a mode is activated manually, the programmed or previous settings are overwritten.

### 4.1 Installing the IQ Control App

The free **IQ Control App** allows the user to control the unit's functions.

#### Preparations:

**Optional.** Make any settings in the home network to guarantee the HERU unit's continuous connection to the internet / Cloud.

1. **Optional.** Connect the HERU unit to the internet-based Cloud service by connecting the internet connection via the port marked LAN.
2. Download the **IQ Control App** to your smartphone from your app store.
3. Create an **HERU IQ** account and log into the app.

## 4.2 Pairing units

1. Make sure the phone's Bluetooth is turned on.
2. On the HERU Bluetooth gateway (1), take a pointed object and briefly press the button inside the hole (2) (the larger hole furthest away from the socket).
3. You have one minute to pair the app with the HERU Bluetooth gateway .
4. Open the IQ Control App, in the app's list of devices, tap the name to pair.
5. The phone will ask if you want to pair (pair and connect).
6. Enter PIN 123456 then OK.
7. If the app is paired with the gateway, the field is highlighted, and the text. Disconnect is displayed.
8. (Optional) Connect your HERU to the internet using a network cable. Use the guide in the IQ Control App to connect the HERU unit to Cloud. Now you have unlimited remote access to your HERU unit.

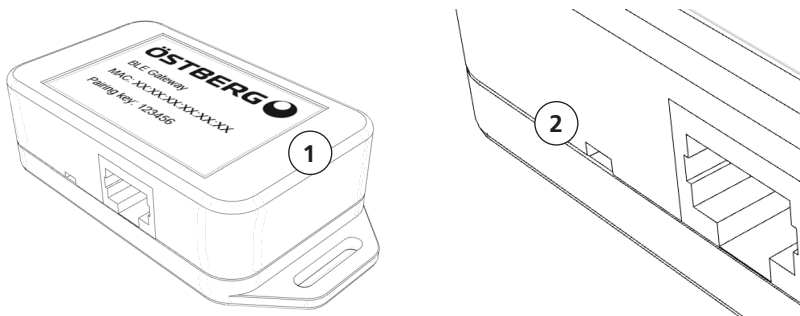

In case of problems when pairing the IQ Control App to the HERU Bluetooth gateway, try the following steps:

- A. In the phone's Bluetooth settings, unpair the bluetooth device. To clear all devices from the HERU Bluetooth gateway, take a pointed object and press and hold the button (see step 2 above) until the led turns off. Then try to pair again.
- B. Turn off Bluetooth on all other phones that are already paired with the HERU unit.
- C. If the Bluetooth connection is lost (Home screen is not available in the app), disconnect the network cable to the HERU Bluetooth gateway and reconnect it again. If still not working, disconnect the power supply to the HERU unit and then connect it again.









## 4.3 Entering the basic settings

1. Open the Home screen, select **Settings**.
2. Select **General**.
3. Select **Language** from the list.
4. Enter **Time**.
5. Select **Measurement system** from the list.
6. Select **Time format** from the list.
7. Select **Time zone** from the list.

## 4.4 IQ Control App

### 4.4.1 Home screen

Shows the status and hotkeys of the Home screen.  
The following symbols can be displayed in the status bar:

1. Home screen
2. Information about the active view
3. Status row – shows available functions
  -  - Status cloud connection
  -  - Bluetooth connection
  - RH** - Air quality compensation for high level of a sensor
  -  - Night cooling active
  -  - Cooler active
  -  - Heater active
  -  - Away mode
  -  - Active program, program no. 5
  -  - Alarm active

Hotkeys to activate or deactivate functions for the modes

4. Temperature
5. Away mode
6. Overpressure
7. Boost

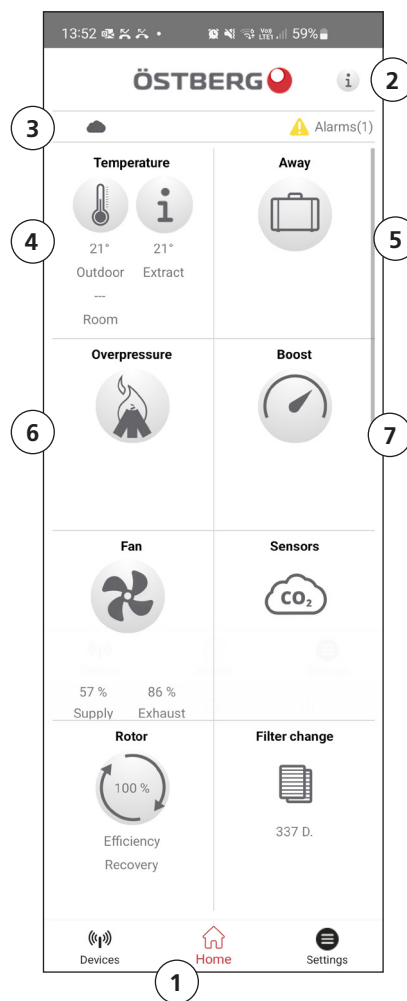

## 4.5 Temperature regulation

1. Press on the thermometer icon.



2. Set desired temperature. Use the buttons - and +.

#### NOTE!

If the economy temperature is activated (**Activate eco. reference value** is on), you can set both **comfort** temperature and **economy** temperature.

3. Press [i] for extend informastion about temperatures.
4. Return to the home screen, by pressing Home.

---

## 4.6 Boost – used for temporarily increased ventilation needs

### 4.6.1 Boosting the unit

1. Press on the **Boost** icon. Operation in boost mode is shown with a green circle around the icon. Deactivate by clicking on the icon again.



**NOTE!** The preset time for boost operation is 30 minutes.

### 4.6.2 Change operating time for boost

1. Choose **Settings**.
2. Select **Service**.
3. Log in. Enter code **1199**.
4. Scroll down to **Boost** and change the operating time.

## 4.7 Overpressure – is used to facilitate the lighting of a fireplace

### 4.7.1 Activate overpressure

1. Press on the **Overpressure** icon. Operation in overpressure mode is stated with a green circle around the icon. Deactivate by clicking on the icon again.



**NOTE!** The preset time for overpressure operation is 15 minutes.

### 4.7.2 Change operating time and compensation for overpressure function

1. Choose **Settings**.
2. Select **Service**.
3. Log in. Enter code **1199**.
4. Scroll down to **Overpressure** and change the operating time.
5. State desired **Offset** value.  
Offset is the difference between supply and exhaust air. Increased to the supply air fan first. If the supply air fan reaches the limit for maximum fan speed, the exhaust air fan is reduced until the difference between the fans corresponds to the offset value.

## 4.8 Activate Away mode

1. Press on the **Away** icon. Operation in away mode is stated with a green circle around the icon. The away mode is active until it is manually deactivated by pressing on the icon again.



### NOTE!

The away mode is prioritised and overrides the program planner if both are active simultaneously.

## 4.9 Scheduling

There are two types of schedules: **Scheduler** for programming the intervals for weekdays and **Holiday scheduler** for programming per date. **Holiday scheduler** overrides **Scheduler** for weekdays. If the different schedules coincide with each other, the schedule with the lowest number overrides the other.

The **Scheduler** can be used in both **comfort** and **economy** mode, if the economy temperature is activated.

1. Choose **Settings**.
2. Select **Scheduler**.
3. Select type of schedule.  
The upper icon automatically activates when one or more program is activated.  
When you deactivate this icon, all programs are deactivated.
4. Select **Program 1** by clicking on it.
5. Enter the selected value.
6. Select **Fan speed**. Select **Min, Std, Max** or **Energy saving mode** from the dropdown list.
7. If economy temperature is activated, select **Temp.mode**. Select **Comfort** or **Economy** from the dropdown list.
8. Click on the button **Save**. The program has activated. In order to deactivate a program, deactivate the icon to its right.
9. To set several different programs, repeat steps 1 – 7 as required.



## 4.10 Activate night cooling

Night cooling is a temperature regulated boost without heat recovery, where the unit is cooled with cold outdoor air as needed.

Night cooling is activated when the Extract air temperature is higher than the set Extract air high value and the out-door temperature is lower than Extract air temperature – (minus) set **In/Out diff.**

Night cooling is deactivated when the Extract air temperature is lower than the set Extract air low or the out-door air temperature is higher than the Extract air temperature – (minus) set **In/Out diff.**

**Temp.evaluation Rest mode** must be activated if the unit is in standby mode and night cooling is requested. **Temp.evaluation Rest mode** checks whether the criteria for activating night cooling has been fulfilled within the set time intervals.

1. Choose **Settings**
2. Select **Service..**
3. Log in. Enter code **1199**.
4. Press **OK**.
5. Select **Setup**.
6. Scroll down to **Night cooling**. Press the **Activate** icon.
7. Enter the selected value.
8. If the unit is in standby and night cooling has been requested, activate **Temp.evaluation Rest mode**.
9. Enter the selected value.

## 4.11 Activate Heater

The **Heater** is a mounted internal heating element, it helps to achieve the adjusted indoor temperature.

**Aftercooling** is a function to cool the **Heater** when the unit is stopped, for example when changing the filter. If **Aftercooling** is activated, the fans continue to run for two minutes after the unit is switched off. We recommend always having **Aftercooling** enabled to prevent the thermal protection from trip and then have to be reset.

1. Choose **Settings**
2. Select **Service..**
3. Log in. Enter code **1199**.
4. Press **OK**.
5. Select **Setup**.
6. Scroll down to **Heater**. Under **Type** – choose **Electric**.
7. If you can't find the **Heater**, activate it in the App under;  
**Installation > Peripherals > Afterheater > Type** – choose **Electric**.

## 4.12 Turn the unit off and on

1. Starting the unit. Connect plug/turn on the safety switch.  
Start the IQ Control App or Press on the display and click on **OK** to the question **Start unit?**
2. Turning off the unit. Open the main menu, scroll down and select **Turn off unit**.

## 4.13 Use the Alarm menu

1. Choose **Settings**, select **Alarms**.
2. Select **Active alarms** to see all active alarms.
3. After managing an active alarm, the active message for the alarm is cleared.
  - Click on the alarm to reset it. In the dialogue box displayed, select **Reset**.
  - In order to reset all active alarms, click on **Reset all** at the bottom in the middle, in **Active alarms**.
4. Select **Alarm history** to see all previous alarms.
5. Return to the home screen.

## 4.14 Change settings

For all available options, see **1270478 – IQC Manual**.

1. Choose **Settings**, select the desired alternative to be changed.
2. Change the parameters to the desired value.
3. Return to the home screen.

## 4.15 Update firmware in the ventilation unit

The firmware can be updated from:

1. The IQ Control App – Android via Bluetooth
2. A PC/MAC computer via Bluetooth.
3. An IQC Display (accessory).

Follow the the instructions in the IQ Control App if a notification about an updated firmware is displayed.

## 5 Maintenance



### WARNING

In accordance with IEC 60335-2-7.12, this apparatus is not intended to be used by people (including children) who have physical, sensory or psychological impairment, or lack of experience and knowledge, unless they have received guidance and instruction on how to use the apparatus by a person who is responsible for their safety. Children must be supervised to ensure that they do not play with the apparatus..



### CAUTION

Always turn off the unit with the IQ Control App before disconnecting the power.



### WARNING

The power supply to the unit must be turned off before service or maintenance is started.



### WARNING

The electric after heater may still be hot after the power has been disconnected for maintenance.

The user may perform maintenance according to the user manual in accordance with IEC 6-335-2-40.

Follow the routines for returning and disposing of replaced parts and packaging material.

### 5.1 Maintenance schedule

Maintenance inspections must be performed according to the schedule below.

The unit must not be repaired directly by the user. Contact the dealer in the event of any fault and if interruptions to operation are noticed.

Operation	Every six months	Every year
Inspect the function for supply and exhaust air	<b>X</b>	
Clean fans and change filter		<b>X</b>

### 5.2 Maintenance

#### 5.2.1 Maintenance every six months

Inspect the function for supply air and exhaust air.

No preparations are required.

1. Inspect the function visually to check that supply air and exhaust air function correctly.

#### 5.2.2 Maintenance every year

Clean fans and change filter.

## 5.3 Preparations

### Tools

- Torx T25 screwdriver
- Flat-blade screwdriver/13 mm socket (HERU S)
- Flat-blade screwdriver (HERU T)

### Disposable items

- Protective gloves
- Breathing protection (minimum class FFP2 as per standard EN149+A1:2009 or equivalent)
- Protective clothing

## 5.4 Open doors and lid

1. Turning off the unit. Cut the power supply and ensure that it cannot be turned on by mistake.
2. Open the unit's cover/doors.

### HERU S:

1. Remove the four corner covers.
2. Loosen the four screws.
3. Lift off the lid.

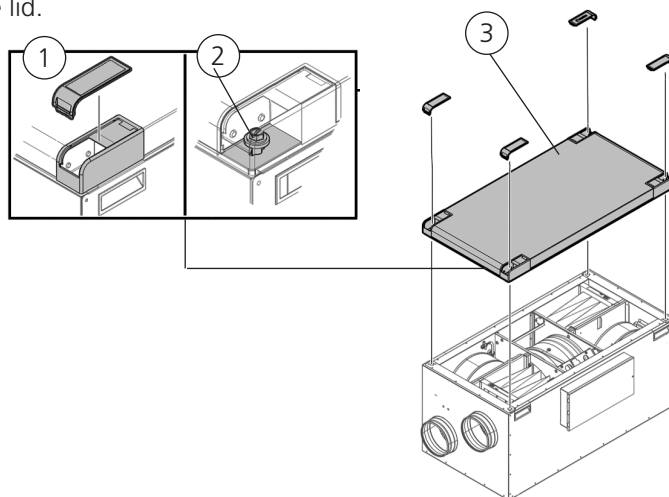

### HERU T:

1. Use a flathead screwdriver to open the lock on the door, Min 10x1.5 mm and Max 15x2 mm tip. The slot is 16x2.3 mm
2. Open the doors .

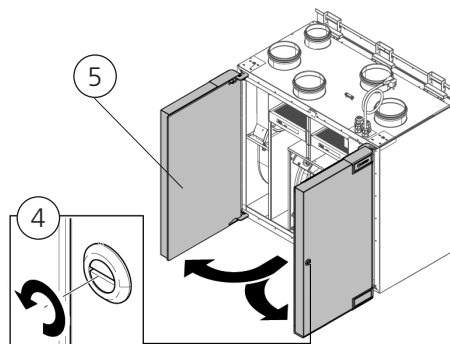

**WARNING**

Watch out for sharp edges and corners on the unit.

**WARNING**

Protective gloves must be worn due to the risk of cuts or injury.

## 5.5 Remove filters and fans.

**WARNING**

Breathing protection and protective clothing must be used due to the risk of breathing in and spreading dust when handling a used filter.

1. Pull the filters straight out.
2. Remove the fans' quick connectors.
3. Unscrew the Torx T25 screws.
4. Carefully draw/lift out the fans from the unit.
5. Unscrew the outer screws from the motor plate.
6. Lift out the motor and fan wheel.

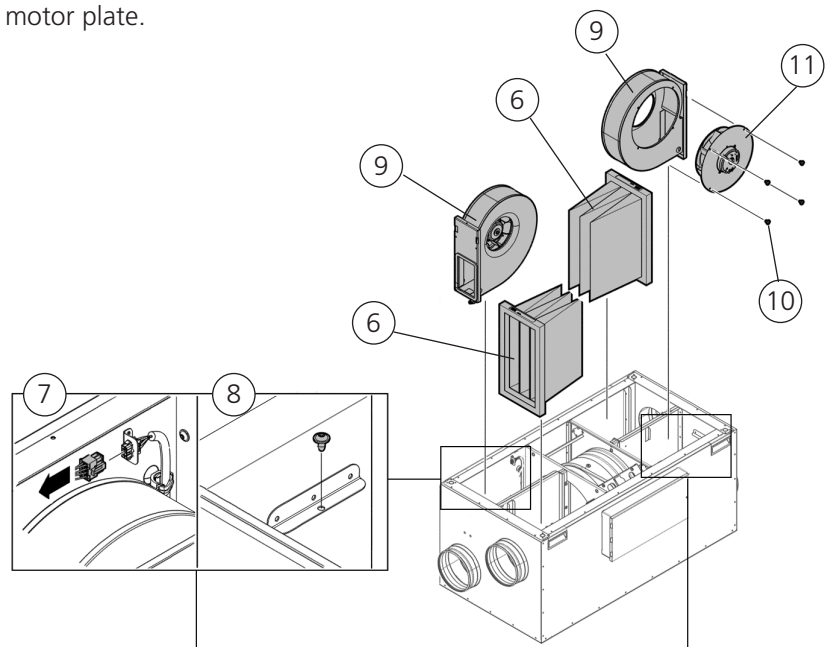
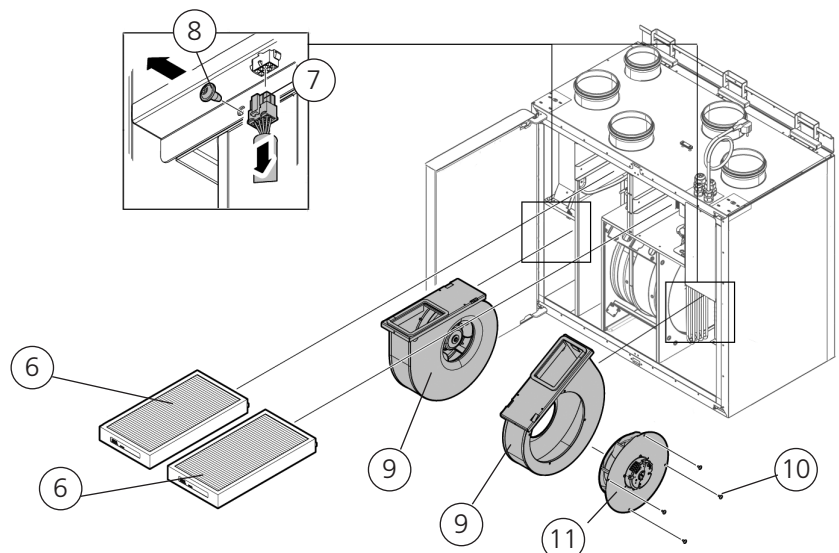
**HERU S:****HERU T:**

7. Inspect the fan wheel and fan housing, and check that it is clean. Wipe with a damp cloth if needed. Wipe the inside of the fan housing if needed.
8. Refit the motor with the fan wheel into the fan housing and tighten the outer screws.
9. Refit the fans in the unit.
10. Tighten the Torx T25 screws.
11. Connect the fans' quick connectors.
12. Fit the new filters.
13. HERU S: Close and lock the cover with the four screws. Install the corner covers.  
HERU T: Close the doors and lock them with the espagnolette bolt.
14. Connect the power supply.
15. If a filter timer is used, this must be reset.
  1. Open the main menu, select **Service**.
  2. Log in. Enter code **1199**.
  3. Press **OK**.
  4. Select **Setup**.
  5. Under **Filter measurement**, click **Reset**.
  6. In the dialogue box displayed, select **Reset**.
  7. Return to the home screen.

## 5.6 Accessories and spare parts

For a complete list of accessories and spare parts for each model, see [www.ostberg.com](http://www.ostberg.com) or contact your nearest HERU dealer.

Function is only guaranteed with accessories from H. Östberg's range.

## 6 Technical data

For current technical data, please see [www.ostberg.com](http://www.ostberg.com).

# 7 Troubleshooting

## 7.1 Alarm

There are two types of alarms: Alarm A and Alarm B. Alarm A is a critical alarm that turns off the unit. Alarm B is an alarm that can affect operation but that does not cause damage to the unit.

When an alarm is activated, a dialogue box opens and a notification of an active alarm is shown in the upper right corner of the IQ Control App. Click on the alarm symbol to see all active alarms.

Alarm	Cause	Operation
<b>Filter</b>	The filters are dirty.	Change the filters.
<b>Filter timer</b>	The set time for filter measurement has been reached.	
<b>Sensor open</b>	The connection to the relay card has been broken. The sensor is broken.	Check which sensor is activated. Check the connection to the relay card and also the connection to the sensor inside the HERU unit. If the fault remains, change the broken sensor.
	The settings for heater and control mode are incorrect.	Adjust the settings for heater and control mode.
<b>Sensor shorted</b>	The connection to the relay card has been broken. The sensor is broken.	Check which sensor is activated. Check the connection to the relay card and also the connection to the sensor inside the HERU unit. If the fault remains, change the broken sensor.
<b>Rotor stop</b>	Rotor, rotor motor, rotor sensor or rotor belt are broken.	Check that the rotor, rotor motor, rotor sensor and rotor belt are intact. Change the broken part if needed.
<b>Overheating</b>	The overheating protection in the electric after heater has triggered.	Check if the manual overheating protection in the electric after heater has triggered. Reset the manual overheating protection and reset the alarm.
<b>Supply air low</b>	The filters are dirty.	Change the filters.
	Rotor belt slips.	Replace the rotor belt.
	The electric after heater does not working.	Ensure that the electric after heater working before start-up. If not, check that the connections are faultless. If the connections are faultless, change the electric after heater.
	The flow direction is not correctly set.	Adjust the settings for flow direction.
<b>Rotor temperature low</b>	The filters are dirty.	Change the filters.
	Rotor belt slips.	Replace the rotor belt.
	The rotor has stuck.	Ensure that the rotor can rotate freely.
<b>Fire alarm</b>	The access to the fire alarm has been activated. Alarm signal from external alarm units.	Check that the correct input function has been selected. Ensure that the external alarm units working as they should before start-up.
<b>Freeze protection</b>	There is not enough heat capacity in the heating coil.	Ensure that the heating coil working before start-up.
	The valve actuator does not open as it should.	Ensure that the valve actuator working before start-up.
<b>Motor failure</b>	No power or signal to the fans and the quick connectors.	Check that the fan is working, otherwise change the broken fan before start-up. Check that the fan has been connected in the right way.
	The fan wheel is blocked.	Ensure that the fan wheel turns freely before start-up.



## 7.2 Other malfunctions

Hardware failure	Cause	Operation
Nothing is displayed on the wireless display.	The batteries are discharged.	Connect the charger.
The display does not react to contact.	The screen lock is activated.	Press on the screen and hold for 3 seconds.
The unit does not start.	The unit receives no power.	Check the fuse, residual current device and connections.
	The activate mode is "Off".	Change the mode to "On".
	The unit is not correctly connected.	Connect the unit correctly.
	Other active alarm.	See <b>7.1 Larm</b> .
The unit has stopped.	The unit receives no power.	Check the fuse and the safety switch.
	There is an active alarm.	Check the cause of the alarm. Once the fault has been resolved, reset the alarm. See <b>7.1 Larm</b> .
	The flow direction is not correctly set.	Adjust the settings for flow direction.
When the unit starts, the IQ COntrol App or the wireless display shows the wrong temperature or the alarm for low temperature.	The unit is not correctly installed.	All electrical installations must be performed by a qualified electrician. Order reinstallation if needed.
The supply air or exhaust air flow is low and or the output is too high.	Grille at air intake is obstructed.	Clean the grille.
	The filters for supply air and exhaust air are dirty.	Change the filters.
The unit's output appears too low.	The filters are dirty.	Change the filters.
	The exhaust air temperature is low.	Find the cause of the low temperature. Check the duct insulation. Check the flow speed in the ducts.
The electric after heater is not hot.	The after heater is not activated. Operation is not permitted.	Activate the after heater in the service menu. Check the installation.

If there are malfunctions that cannot be solved with the aid of this information, contact your electrician or dealer.

For a complete list of accessories and spare parts for each model, see [www.ostberg.com](http://www.ostberg.com) or contact your nearest HERU dealer.

## 7.3 Troubleshooting chart

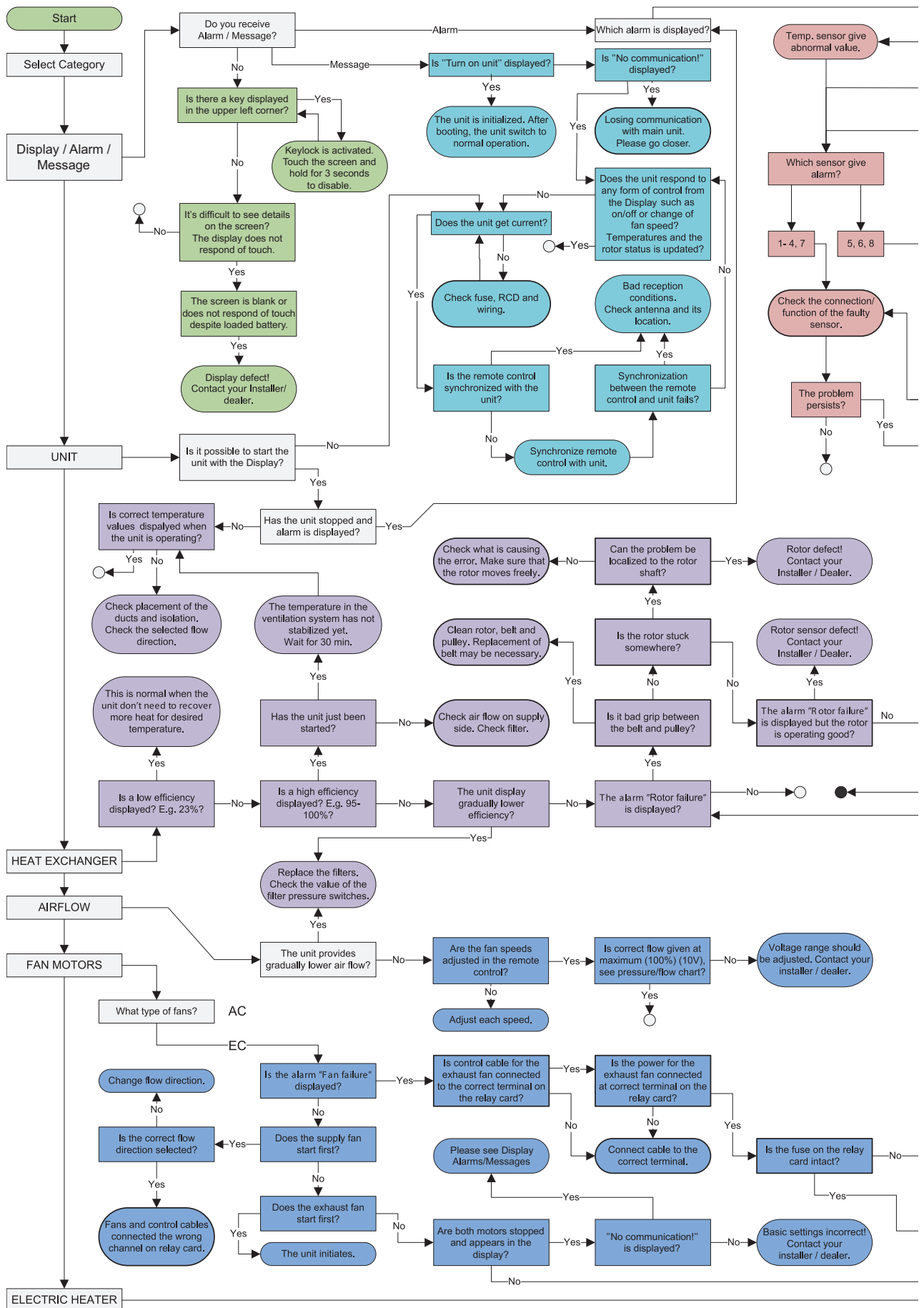

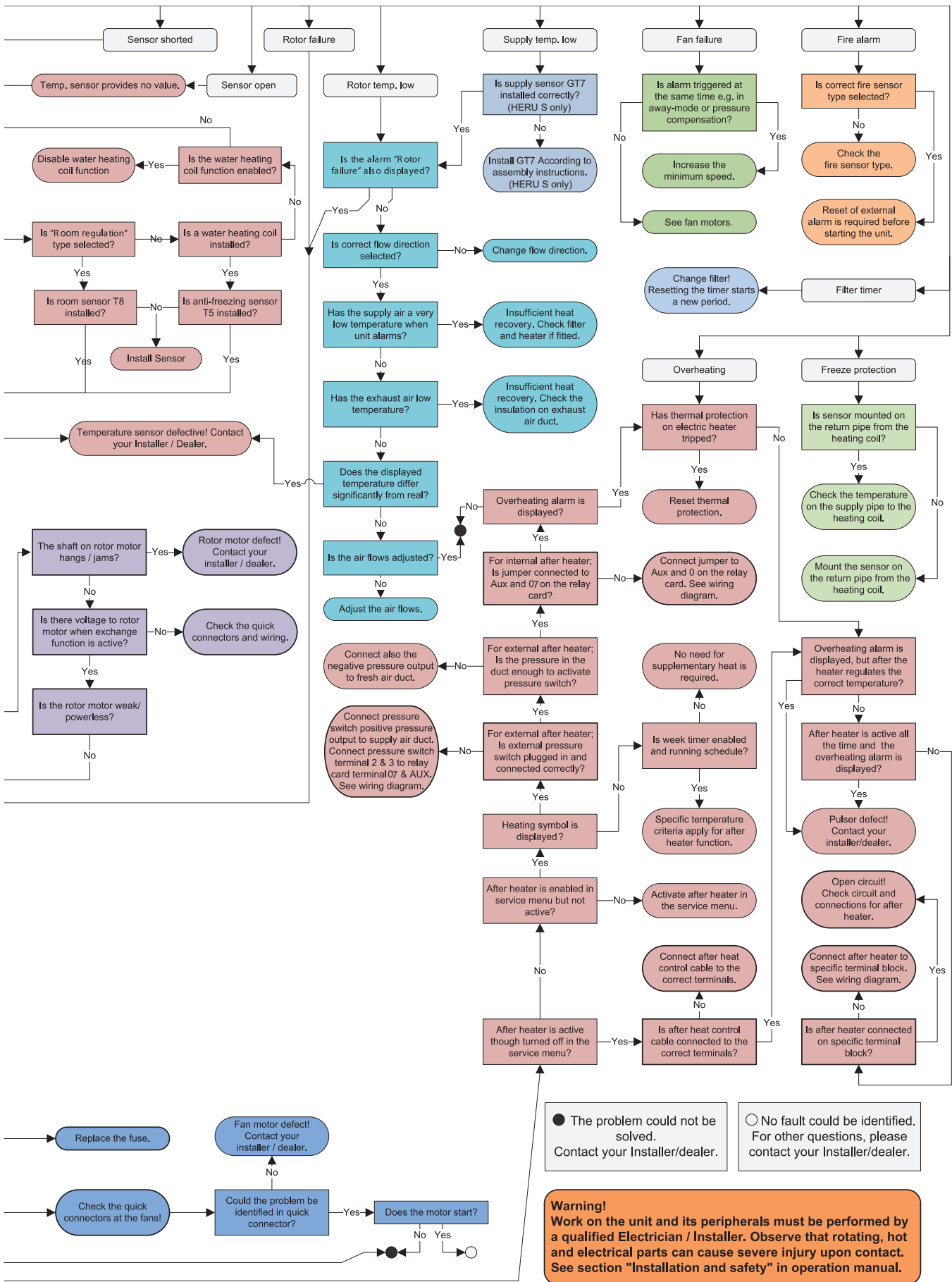

# Appendix 1 IQ Control App – Setup Wizard

The Setup Wizard is a easy setup tool for your HERU air handling unit. Follow the steps.

You find it under: Settings > Service > code 1991 > Setup Wizard.

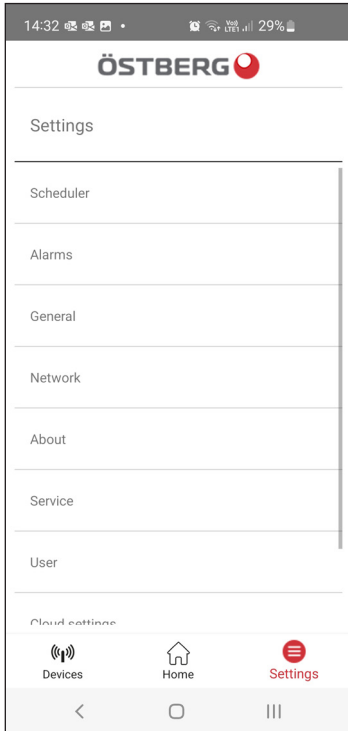

Choose Settings

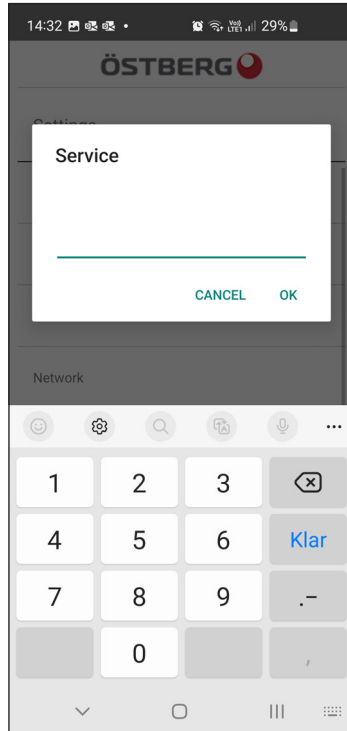

Choose Service

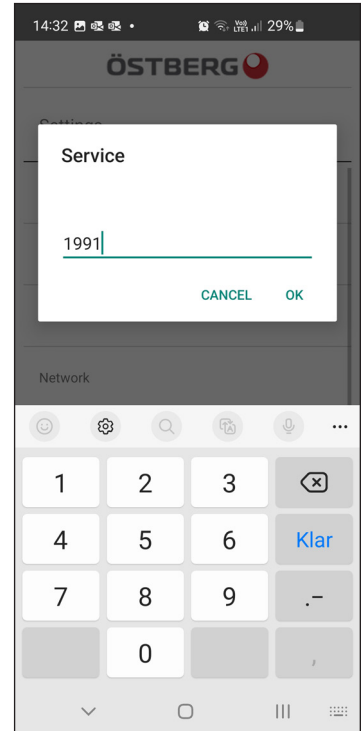

Write 1991

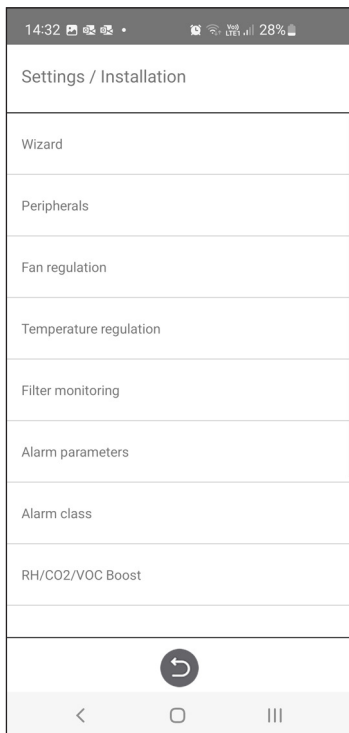

Choose Setup Wizard

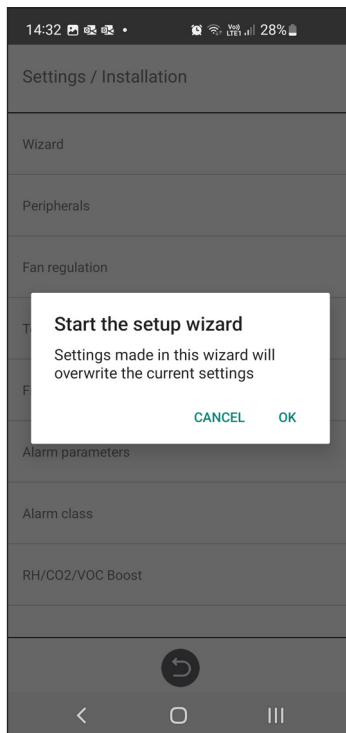

Setup Wizard start

### 1.1 Step 1 – RH/CO2/VOC Boost

#### Sensor type

Select the type of sensor and set the limit value for when fan compensation will activate.

If the limit value is exceeded, the supply and exhaust air flow will be increased steplessly.

When using more than one sensor, the value that is greatest is prioritized.

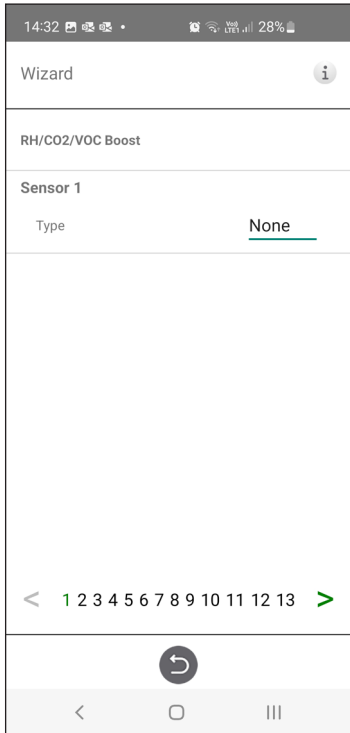

Setup Wizard –1 – RH/CO2/VOC Boost

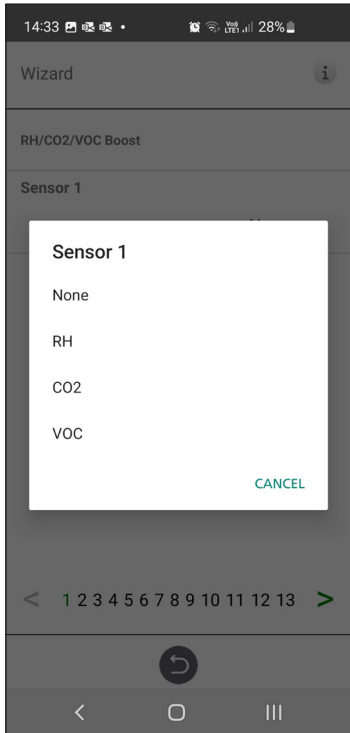

Setup Wizard –1 – RH/CO2/VOC Boost – choices

### 1.2 Step 2 – Heating and cooling

#### After Heater

Selection of which type of after heater that is installed. For electric heater, after-cooling function can also be set. For water, freeze protection parameters can be set:

- Hold temperature: When the plant is switched off, the water coil is kept warm so that the return water temperature is the same as the holding temperature set point.
- Limit B: Temperature limit value where heat valve is forced to full open.
- Limit A: Temperature limit where also the plant is stopped if it is in operation.

#### Pre-heater

Selection of which type of pre heater that is installed. Temperature set point is set to when pre heater is to start support heat the cold fresh air.

The pre-heater is controlled against the temperature at the outdoor air filter and is activated when the temperature in the outdoor air falls below the set point.

#### Cooling

Selection of which type of cooling device that is installed.

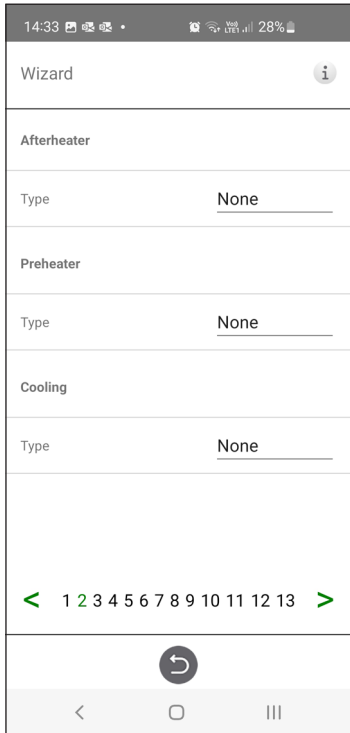

Setup Wizard – 2 – After heater

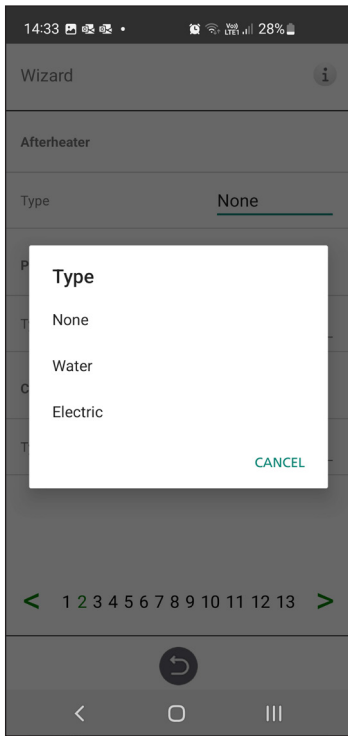

Setup Wizard – 2 – After heater – choices

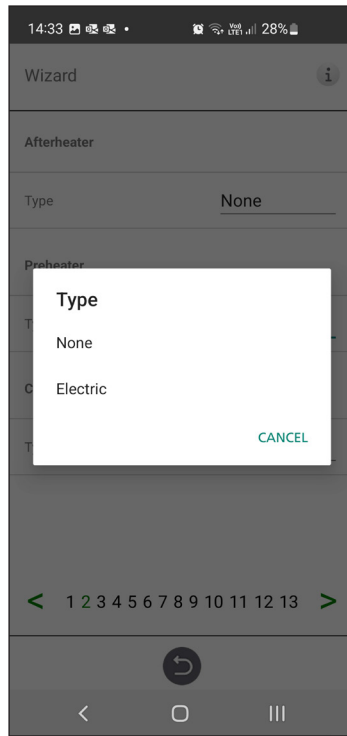

Setup Wizard – 2 – Pre heater– choices

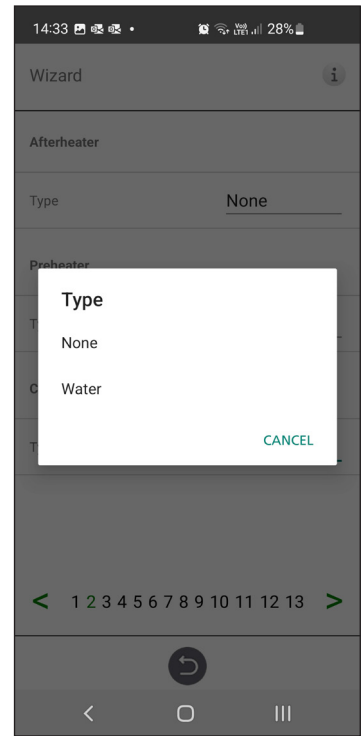

Setup Wizard – 2 – Cooling – choices

### 1.3 Step 3 – Temp regulation

#### Regulation Type

- Supply compare the temperature set point against the temperature in the supply air.
- Exhaust air compare the set point against the temperature in the extract air and regulates the temperature in the supply air between the set Min/Max limits.
- Room compare the set point against temperature from the room sensor and regulates the temperature in the supply air between set Min/Max limits.

Exhaust S/W and Room S/W enable automatic changeover of control type to supply air regulation in wintertime.

Changeover can be made on temperature criterion, date or via external input.

When Exhaust S/W or Room S/W is selected, a temperature offset factor can be set. This factor only affects supply air regulation in winter.

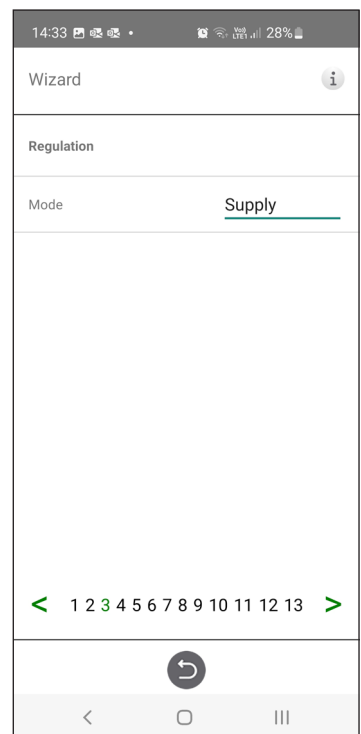

Setup Wizard – 3 – Temp regulation / Supply

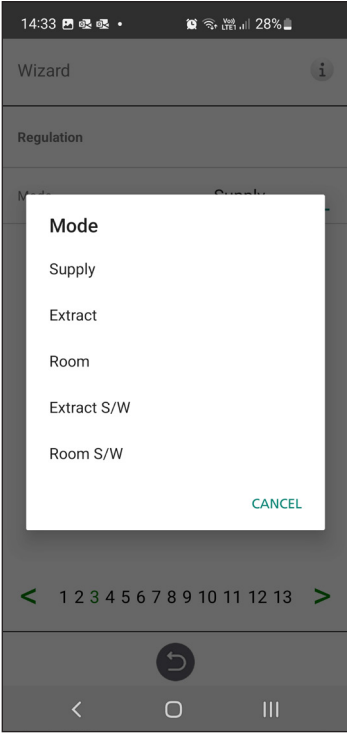

Setup Wizard – 3 – Temp regulation – choices

### 1.4 Step 4 – Temp set point & Supply temp low

#### Set point Max limit:

Set a maximum limit on the temperature set point setting.

Extra economy temperature set point can be activated, which allows for two temperature set points in the scheduler.

#### Supply air temperature Low:

- Limit A: Temperature limit when alarms for low supply air temperature will be given.
- Limit B: At which temperature limit the fan reduction will be activated.
- Fan reduction: Reduction of supply air fan. Min 10%, Max % diff. between Max and Min speed.

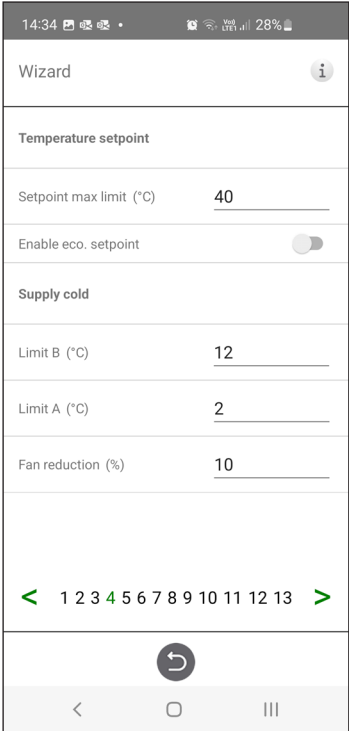

Setup Wizard – 4 – Temp set point

## 1.5 Step 5 – Switches

### External inputs – Contact function:

Choice of contact function from external equipment.

NO: Normally open,  
NC: Normally closed.

- Fire alarm:
- Fire mode: Function of fans in case of fire alarm.
- Forced speed: If fan is forced into operation, the % output signal will be used.

Automatic reset allows the unit to return to normal operation automatically when the external fire alarm is reset.

### Emergency Stop / Service switch:

Possibility to use Emergency Stop / Service switch via input D6. If Expansion card is activated, the function is activated via input DI9.

### External inputs - Signal type:

Choice of signal type from external equipment.

- "Pulse" is used for instant contact function.
- "Switch" is used for sustained contact function.

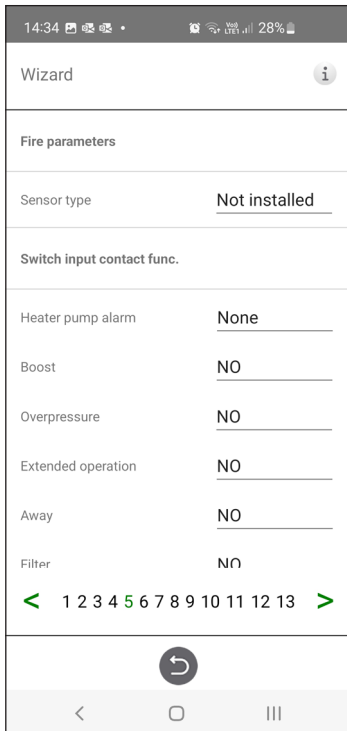

Setup Wizard – 5 – Switches

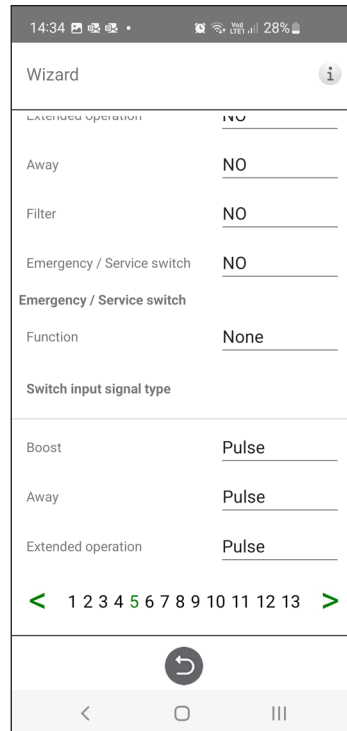

Setup Wizard – 5 – Switches

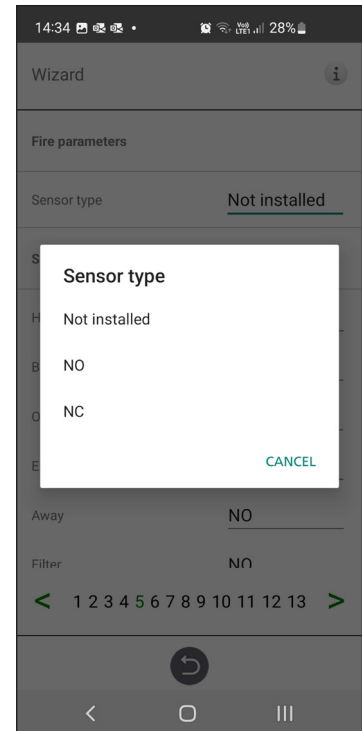

Setup Wizard – 5 – Switches – sensor type choice



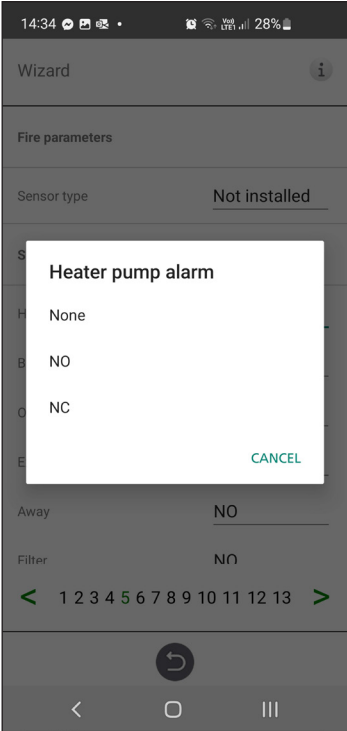

Setup Wizard – 5 – Switches – heater pump alarm choice

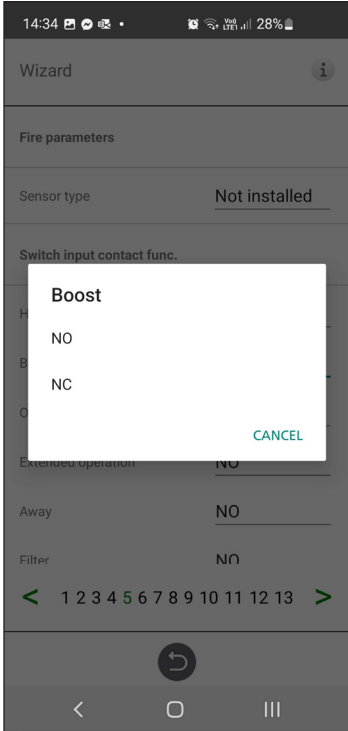

Setup Wizard – 5 – Switches – boost choice

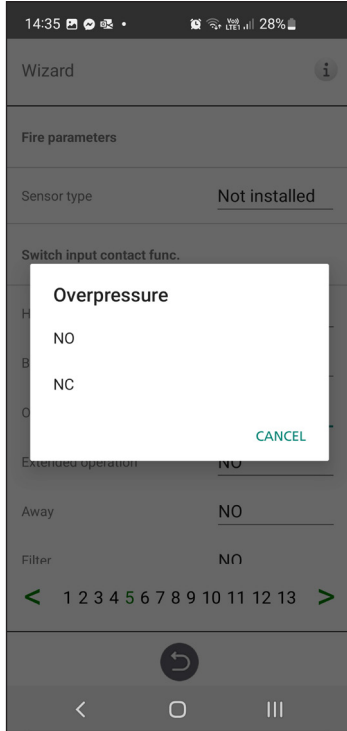

Setup Wizard – 5 – Switches – overpressure choice

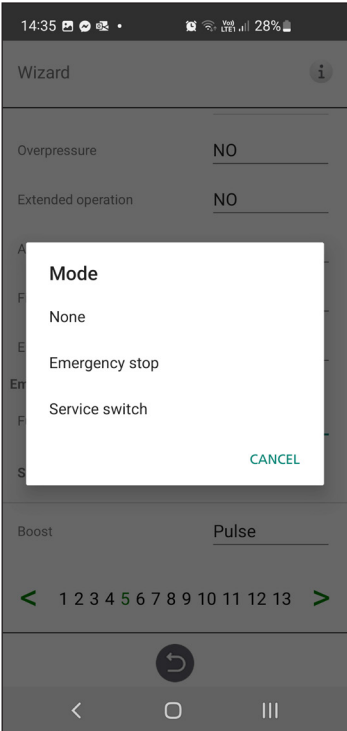

Setup Wizard – 5 – Switches – mode choice

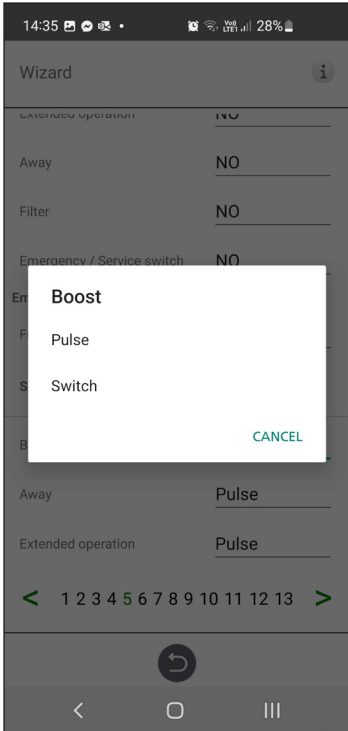

Setup Wizard – 5 – Switches – Boost choice

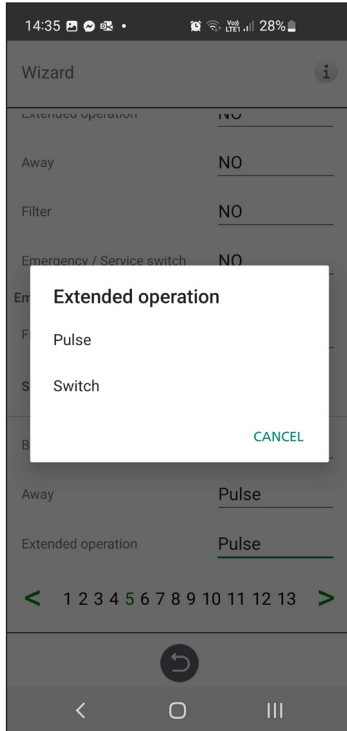

Setup Wizard – 5 – Switches – Ext. Operation choice

## 1.6 Step 6 – Alarm class

Settings of which alarm class that respective alarm should have.

### Two levels can be selected:

- A-alarm: A critical alarm that will stop the ventilation unit.
- B-alarm: A non-critical alarm that keeps the ventilation unit in operation.

### Alarm outputs:

- A-relay state: Contact function during normal operation.
- B-relay state: Contact function during normal operation.
- Run-relay state: Contact function during normal operation.

### Alarm relay alerts:

Which alarms that will affect alarm output. Depending on the alarm class, the A-relay or the B-relay is affected.

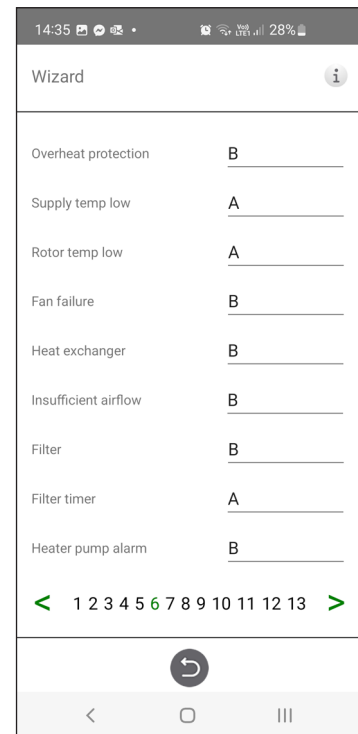

Setup Wizard – 6 – Alarm class

## 1.7 Step 7 – Filter measurement

### Filter Measurement:

Type of filter control.

- Period: Selected by default. Gives an alarm when the service period has expired. Reset starts new service period.
- Diff. switch: Scheduled filter measurement at selected day & time (requires accessories).
- Diff. sensor: Scheduled filter measurement at selected day & time. Compare measured value against set final pressure drop (requires accessories).

- Speed increase: In CPC control of fans, the output signal of the fans can be used as a reference when measuring filter clogging. The limit value for filter alarms is the saved reference value of the fans increased by the set value for speed increase. Speed increase means keeping a constant pressure in the duct by increasing the fans' output signal to compensate for clogged filters (requires accessories).

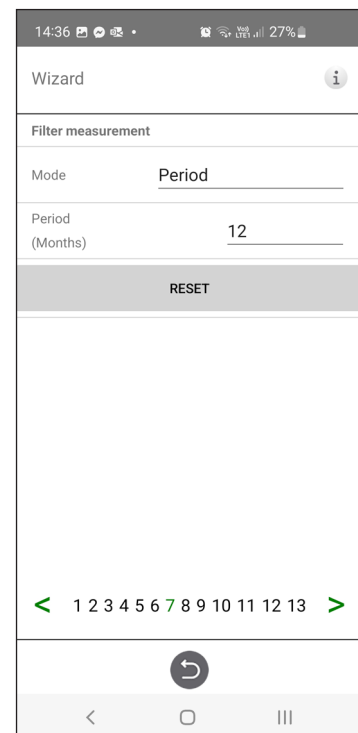

Setup Wizard – 7 – Filter measurement – Period

### 1.8 Step 8 – Dampers

**Damper:**

Opening time setting for dampers. Acts as start-up delay of the extract air fan to allow time for dampers to open.

For opening times, see separate data sheet for damper motor.

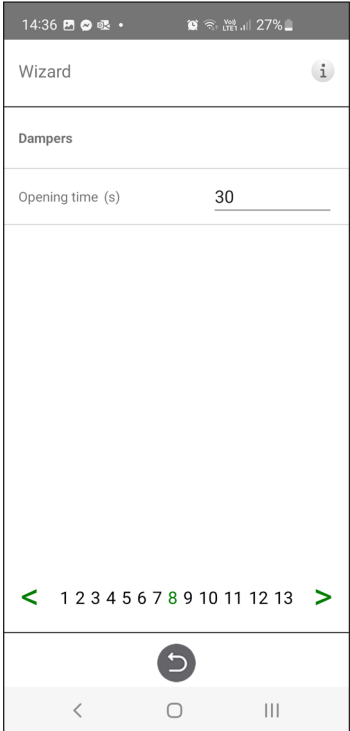

Setup Wizard – 8 – Dampers

### 1.9 Step 9 – Flow and regulation

**Flow direction:**

Can be set Standard or Opposite.

The "Opposite" setting is only used on ventilation units that have a design that allows the flow direction to be changed. See manual for more details.

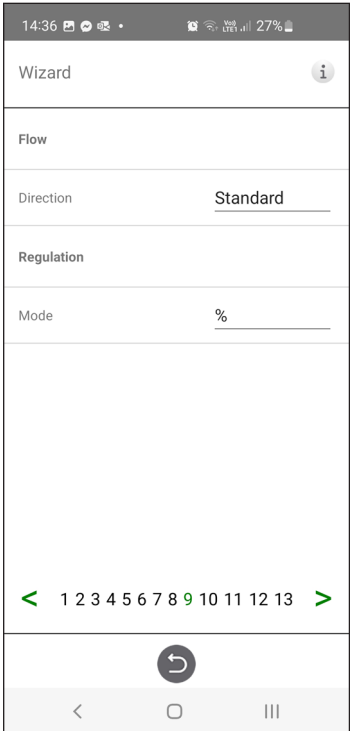

Setup Wizard – 9 – Flow and regulation

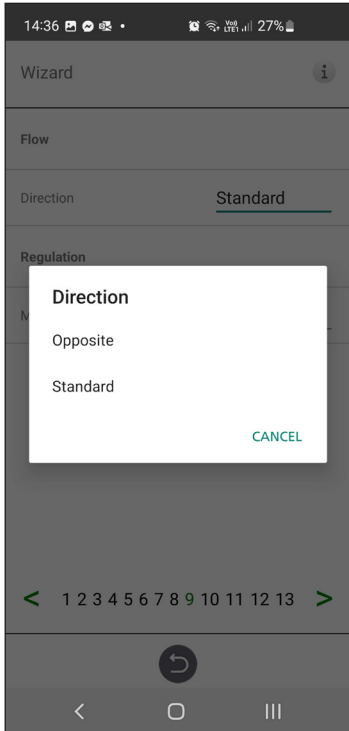

Setup Wizard – 9 – Flow and regulation – direction

## 1.10 Step 10 – Standard fan speed

### Standard fan speed:

When entering the setup page, all program parameters that affect the flow of the fans are temporarily deactivated and the program is entering adjustment mode.

When leaving the setup page, the unit returns to normal operation.

The standard fan speed is the position where adjustment of the ventilation system shall be made. The supply and exhaust air flow can be adjusted individually.



Setup Wizard – 10 – Standard fan speed

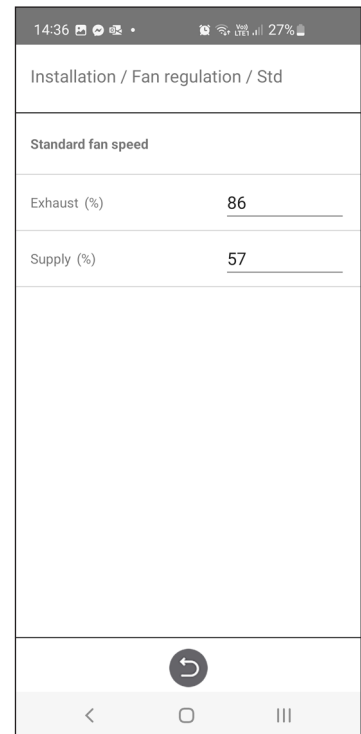

Setup Wizard – 10 – Std fan speed settings

## 1.11 Step 11 – Min fan speed

### Min Speed:

When entering the setup page, all program parameters that affect the flow of the fans are temporarily deactivated and the program is entering adjustment mode. When leaving the setup page, the unit returns to normal operation.

The exhaust air flow can be adjusted. The supply air flow is calculated automatically based on the ratio in Standard fan speed. In the case of VAV regulation with static offset, the supply and exhaust air flow can be set individually.



Setup Wizard – 11 – Mix fan speed



Setup Wizard – 11 – Min fan speed settings

## 1.12 Step 12 – Max fan speed

### Max Speed:

When entering the setup page, all program parameters that affect the flow of the fans are temporarily deactivated and the program is entering adjustment mode. When leaving the setup page, the unit returns to normal operation.

The exhaust air flow can be adjusted. The supply air flow is calculated automatically based on the ratio in Standard fan speed. In the case of VAV regulation with static offset, the supply and exhaust air flow can be set individually.



Setup Wizard – 12 – Max fan speed

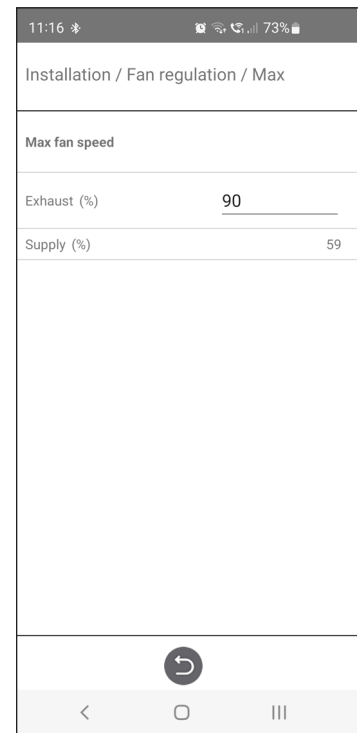

Setup Wizard – 12 – Max fan speed settings

## 1.13 Step 13 – Save settings

Press Yes to save all settings made in the wizard. Previously set values will be overwritten.

Press Cancel to discard all settings made in the wizard and return to the previous menu.

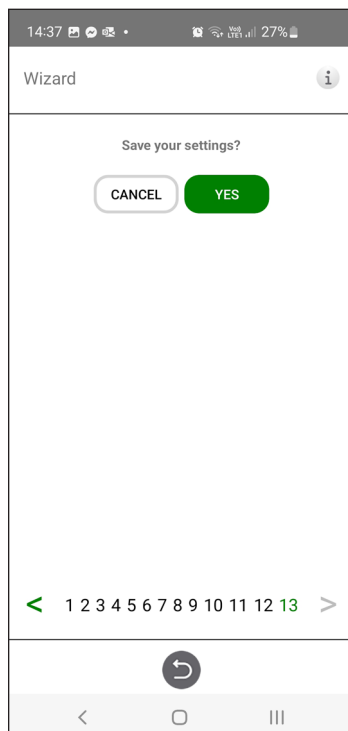

Setup Wizard – 13 – Save settings





energy  
efficient  
ventilation

**ÖSTBERG** 

**H ÖSTBERG AB**

Box 54, SE-774 22 Avesta, Sweden

Phone: +46 226 860 00

E-mail: [info@ostberg.com](mailto:info@ostberg.com)

[www.ostberg.com](http://www.ostberg.com)

1270525\_2.01