



Other languages in digital format can be downloaded at www.ostberg.com



1	SAFETY	5
1.1	Warnings	5
1.2	General safety	5
1.3	Product label	6
2	TRANSPORT AND STORAGE	9
2.1	General	9
2.2	Checking the delivery	9
3	INSTALLATION	10
3.1	System overview	11
3.2	Preparation and placement	12
3.3	Internet connection	14
3.4	HERU S	14
3.4.1	Disassemble the unit to reduce the weight when installing HERU S	14
3.4.2	Installation HERU S	16
3.4.3	Connect the ducts to the unit	18
3.4.4	Install the duct sensor GT7	18
3.4.5	Mount the Bluetooth dongle	18
3.4.6	Opposite flow direction	19
3.4.7	Mounting the parts after installing HERU S	20
3.5	HERU T	21
3.5.1	Disassemble the unit to reduce the weight when installing HERU T	21
3.5.2	Installation HERU T	23
3.5.3	Cooker hood	25
3.5.4	Connect the ducts to the unit	26
3.5.5	Mount the Bluetooth dongle	26
3.5.6	Mounting the parts after installing HERU T	27
3.6	Connecting the unit to the power source	29
3.7	Connecting Modbus to external control equipment	29
3.8	Final routines	30
4	COMMISSIONING	31
4.1	Installing the IQ Control App	31
4.1.1	Create new account	31
4.1.2	Delete user	32
4.1.3	Change Password	32
4.1.4	Forgot password	32
4.2	Connection via IQC Bluetooth module	33
4.2.1	Reset of IQC Bluetooth module	33
4.3	Connection via Cloud	34
4.3.1	Remove aggregates from Cloud	34
4.4	Updating software	35
4.4.1	Update via an Android phone	35
4.4.2	Update via PC	35
4.4.3	Update via MAC	36
4.5	First start-up of the HERU unit	36
4.5.1	Update firmware in the ventilation unit	36
4.6	Configuring the unit	37
4.7	Adapting the unit for airflow in the opposite direction	38
4.8	Configuring the unit for Modbus	38
4.8.1	Configuring the unit for Modbus via RS485	38
4.8.2	Configuring the unit for Modbus with TCP/IP	38
5	TECHNICAL DATA	39
6	CONNECTIONS MAIN BOARD	41
7	CONTROL DIAGRAM	43
APPENDIX 1	COMMISSIONING PROTOCOL HERU S /T	44
1.1	Notes	45
APPENDIX 2	IQ CONTROL APP – SETUP WIZARD	46

The manufacturer cannot be held liable for injury and damage to people or property that are caused by incorrect installation, start up and/or incorrect use of the unit and/or failure to follow the processes and instructions that are set out in the user manual "Operation & maintenance". For safety reasons it is essential to follow the instructions in the user manual.

The warranty will be immediately invalidated in the event of injury that is caused by failure to follow the instructions. Installation and commissioning must be performed by an authorized personnel according to local regulations in order for the warranty to apply.



CAUTION!

The commissioning protocols must be completed for the warranty to apply.
Available at the end of the manual.

Shortcuts:

- **Log in Installation menu:** Enter code 1991
- **Log in Service menu:** Enter code 1199.
- **Bluetooth pairing code:** 123456
- **Download the latest firmware version:** [Firmware.](#)
- **Download complete Modbus register:** [Modbus.](#)

FIRMWARE



MODBUS



- **Download the app:** [HERU IQ Control App.](#)

APPLE

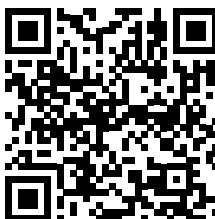

GOOGLE



- **Download wiring diagrams via the links below**

HERU S

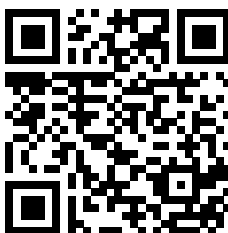

HERU T

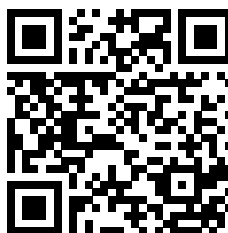

Information about the products at www.ostberg.com

1 Safety

1.1 Warnings

**WARNING!**

A warning states a risk of personal injury.

**CAUTION!**

A caution states a risk of damage to equipment.

1.2 General safety

**WARNING!**

All electrical installations must be performed by a qualified electrician.

**WARNING!**

Power must be cut to the unit for two minutes before work can be started.

**WARNING!**

Ensure that the power cable is not damaged during mounting and installation.

**WARNING!**

The unit may not be started until the installation is completely finished and the ducts have been connected.

**WARNING!**

The safety switch must not be used for normal starting and stopping of the unit. Use the IQ Control App.

**WARNING!**

The safety switch must be switched off when the cover of the electrical distribution box or the doors/cover of the unit are opened/removed from the unit.

**WARNING!**

The unit must always be equipped with a type A or B, 30 mA residual current device (RCD). Units without plugs must be installed with a safety switch, which must be mounted close by.

**WARNING!**

Units with plugs must be fused with a C10 A-fuse.

**WARNING!**

Units without plugs must be fused with a 2xC10 A-fuse together with 2.5 mm² conductor.

**WARNING!**

All operations on the unit and its peripheral equipment must be performed in accordance with local laws and regulations.

**WARNING!**

Watch out for sharp edges and corners on the unit.



WARNING!

Pay attention to the weight of the unit and its parts during mounting and maintenance.



WARNING!

Rotating, hot and electrical components can cause serious injuries.



WARNING!

Ducts must be connected and doors/cover must be closed and locked before starting up the unit. Risk of personal injury from rotating parts.



CAUTION!

Dampers with spring return must be installed in the ducts for outside and exhaust air. The dampers prevent the formation of condensation and possible damage to the unit's internal components, in case of scheduled stops or loss of operation.



CAUTION!

Do not connect an exhaust air type tumble dryer or drying cabinet to the system due to the high air humidity.



CAUTION!

If the unit is installed when it is cold outside/in the winter and it will not immediately be put into use, the ducts must be plugged again otherwise there is a risk of condensation and the unit freezing.

1.3 Product label

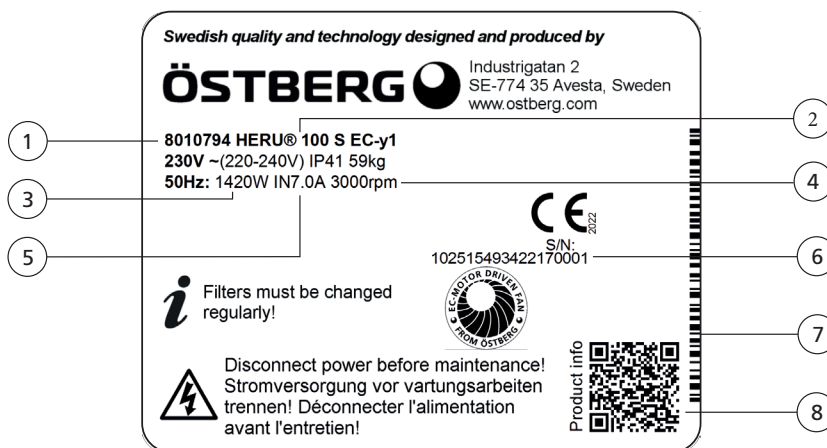

Example of product label

- 1 Item number
- 2 Product name
- 3 Maximum power including heater
- 4 RPM at maximum power
- 5 Current at maximum power including heater
- 6 Serial number
- 7 Serial number as bar code
- 8 QR-code for product web page



EU DECLARATION OF CONFORMITY

We hereby confirm that our products comply with the requirements in the following EU-directives and harmonised standards and regulations.

Manufacturer: H. ÖSTBERG AB
 Industrigatan 2
 SE-774 35 Avesta, Sweden
 Tel No +46 226 860 00
 Fax No +46 226 860 05
<http://www.ostberg.com>
info@ostberg.com
 VAT No SE556301220101



Products: Bidirectional ventilation unit RVU: HERU® 95 T EC, HERU® 100 T EC, HERU® 160 T EC, HERU® 200 T EC, HERU® 300 T EC, HERU® 100 S EC, HERU® 160 S EC, HERU® 200 S EC, HERU® 300 S EC, HERU® 70 K EC, HERU® 50 LP EC, HERU® 90 LP EC, HERU® 180 S EC 2, HERU® 250 T EC, HERU® 130 S EC, HERU® 250 S EC
 Bidirectional ventilation unit NRVU: HERU® 400 T EC, HERU® 600 T EC, HERU® 800 T EC, HERU®, 1200 T EC, HERU® 400 S EC, HERU® 600 S EC, HERU® 800 S EC, HERU® 1200 S EC, HERU® Select

This EU declaration is applicable for products including our accessories for mounting and installation only if the installation is made in accordance with the enclosed installation instructions and that the product has not been modified.

Radio Equipment Directive (RED) 2014/53/EU

Harmonised standards:

- EN 300 220-2:2018 V3.1.1
- EN 303 446-1:2019 (EN 55014-1:2017, A11, EN 55014-2:2015, EN IEC 61000-3-2:2019, EN 61000-3-3:2013, A1)
- EN 301 489-3:2019

Machinery Directive (MD) 2006/42/EC

Harmonised standards:

- EN ISO 12100:2010
- EN ISO 13857:2019
- EN 60204-1:2018
- EN 60335-1:2012, AC 1, A 13 R1, A 11, A 12, A 13, A 1, A 14, A2, A15
- EN 60335-2-40:2003, A13, A2, A12, A1, A11, C1, C2
- EN 60335-2-30:2010, A11, A1, A12

Ecodesign Directive 2009/125/EC

Harmonised regulation:

- 1253/2014 Ecodesign requirements for ventilation units
- 1254/2014 Energy labeling of residential ventilation units

Standards:

- RVU: SS-EN 13141-7:2021 or NRVU: SS-EN 13053:2019

RoHS Directive 2011/65/EU

Harmonised standards:

- EN IEC 63000:2018

Avesta 2022-04-25

Mikael Östberg
 Product Manager



GB DECLARATION OF CONFORMITY

We hereby confirm that our products comply with the requirements in the following UK legislations and designated standards.

Manufacturer: H. ÖSTBERG AB
 Industrigatan 2
 SE-774 35 Avesta, Sweden
 Tel No +46 226 860 00
 Fax No +46 226 860 05
<http://www.ostberg.com>
info@ostberg.com
 VAT No SE556301220101



Products: **Bidirectional ventilation unit RVU:** HERU® 95 T EC, HERU® 100 T EC, HERU® 160 T EC, HERU® 200 T EC, HERU® 300 T EC, HERU® 100 S EC, HERU® 160 S EC, HERU® 200 S EC, HERU® 300 S EC, HERU® 70 K EC, HERU® 50 LP EC, HERU® 90 LP EC, HERU® 180 S EC 2, HERU® 250 T EC, HERU® 130 S EC, HERU® 250 S EC
Bidirectional ventilation unit NRVU: HERU® 400 T EC, HERU® 600 T EC, HERU® 800 T EC, HERU®, 1200 T EC, HERU® 400 S EC, HERU® 600 S EC, HERU® 800 S EC, HERU® 1200 S EC, HERU® Select

This GB declaration is applicable for products including our accessories for mounting and installation only if the installation is made in accordance with the enclosed installation instructions and that the product has not been modified.

Radio Equipment Regulations 2017, S.I. 2017 No. 1206

Designated standards:

- EN 300 220-2:2018 V3.1.1
- EN 303 446-1:2019 (EN 55014-1:2017, A11, EN 55014-2:2015, EN IEC 61000-3-2:2019, EN 61000-3-3:2013, A1)
- EN 301 489-3:2019

The Supply of Machinery (Safety) Regulations 2008, S.I. 2008 No. 1597

Designated standards:

- EN ISO 12100:2010
- EN ISO 13857:2019
- EN 60204-1:2018
- EN 60335-1:2012, AC 1, A 13 R1, A 11, A 12, A 13, A 1, A 14, A2, A15
- EN 60335-2-40:2003, A13/AC, A2, A12, A1, A11, AC1, AC2

Standard:

- EN 60335-2-30:2010, A11, A1, A12

The Ecodesign for Energy-Related Products and Energy Information (Amendment) (EU Exit) Regulations 2019, S.I. 2019 No. 539

Retained regulation:

- 1253/2014 Ecodesign requirements for ventilation units
- 1254/2014 Energy labeling of residential ventilation units

Standards:

- RVU: SS-EN 13141-7:2010 or NRVU: SS-EN 13053:2019

Restriction of the Use of Certain Hazardous Substances in Electrical and Electronic Equipment Regulations 2012, S.I. 2012 No. 3032

Designated standards:

- EN IEC 63000:2018

Avesta 2024-05-21

 Mikael Östberg
 Product Manager

This document is digitally signed.

2 Transport and storage

2.1 General

The HERU unit must be stored in a protected and dry space before installation.

2.2 Checking the delivery

1. Inspect the unit carefully upon delivery to check for any damage that may have occurred during transport. Immediately inform the manufacturer in the event of severe damage.

NOTE! The manufacturer cannot be held liable for damage to the unit during transport, even if the manufacturer has appointed the shipping agent.

2. Check that the delivery contains all ordered parts.
The following parts will be included in the HERU delivery:

- Assembled HERU unit
- Labels:
 - Air direction labels

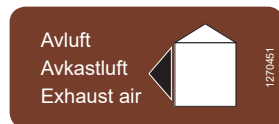

(only HERU T 100/160)

- Energy label (example)

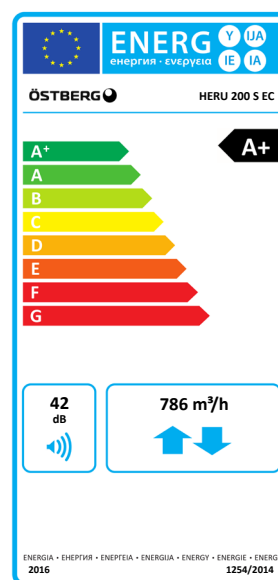

- Cables:
 - RJ-45 cable with Bluetooth dongle
 - GT7 cable (only for HERU S)
 - Cord set with plug (excluding HERU S 200/300 and HERU T 200/300)
- 2 filters
- Vibration damper x2 (HERU T 100), x3 (HERU T 160)
- Information sheet
- Installation manual
- Manual for operation and maintenance

3. Contact your dealer if anything is missing.

3 Installation

**WARNING!**

Power must be cut to the unit for two minutes before work can be started.

**WARNING!**

Make sure that the electricity is switched off during the entire assembly process.

**WARNING!**

The unit may not be started until the installation is completely finished and the ducts have been connected.

**WARNING!**

All electrical installations must be performed by a qualified electrician.

**WARNING!**

The safety switch must be switched off when the cover of the electrical distribution box or the doors/cover of the unit are opened/removed from the unit.

**WARNING!**

All operations on the unit and its peripheral equipment must be performed in accordance with local laws and regulations.

**WARNING!**

Rotating, hot and electrical components can cause serious injuries.

**CAUTION!**

Do not connect an exhaust air type tumble dryer or drying cabinet to the system due to the high air humidity.

**CAUTION!**

If the unit is installed when it is cold outside/in the winter and it will not immediately be put into use, the ducts must be plugged again otherwise there is a risk of condensation and the unit freezing.

**CAUTION!**

Installation and commissioning must be performed by an authorized personnel according to local regulations in order for the warranty to apply.

**CAUTION!**

The commissioning protocols must be completed for the warranty to apply.
Available at the end of the manual.

3.1 System overview



CAUTION!

The commissioning protocols must be completed for the warranty to apply.
Available at the end of the manual.

HERU S for placement in warm or cold space, e.g. in the attic.

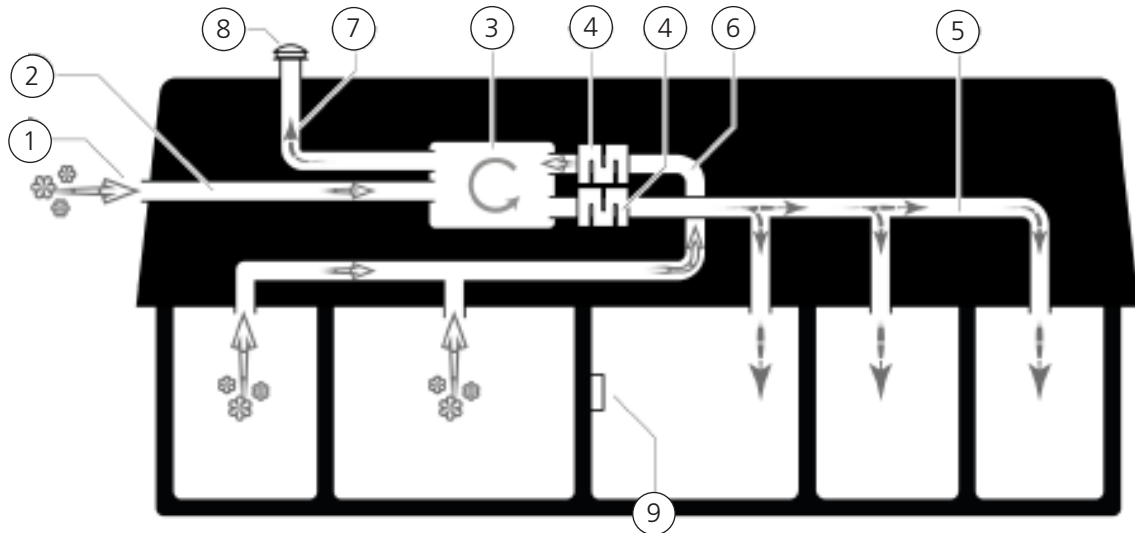

- | | |
|--------------------------------|---|
| 1. Intake grille for fresh air | 6. Extract air duct |
| 2. Fresh air duct | 7. Exhaust air duct |
| 3. HERU S energy recovery unit | 8. Roof hood exhaust air |
| 4. Silencers | 9. IQ Control App or wireless IQC display |
| 5. Supply air duct | |

HERU T for placement in warm or cold space, e.g. in the laundry.

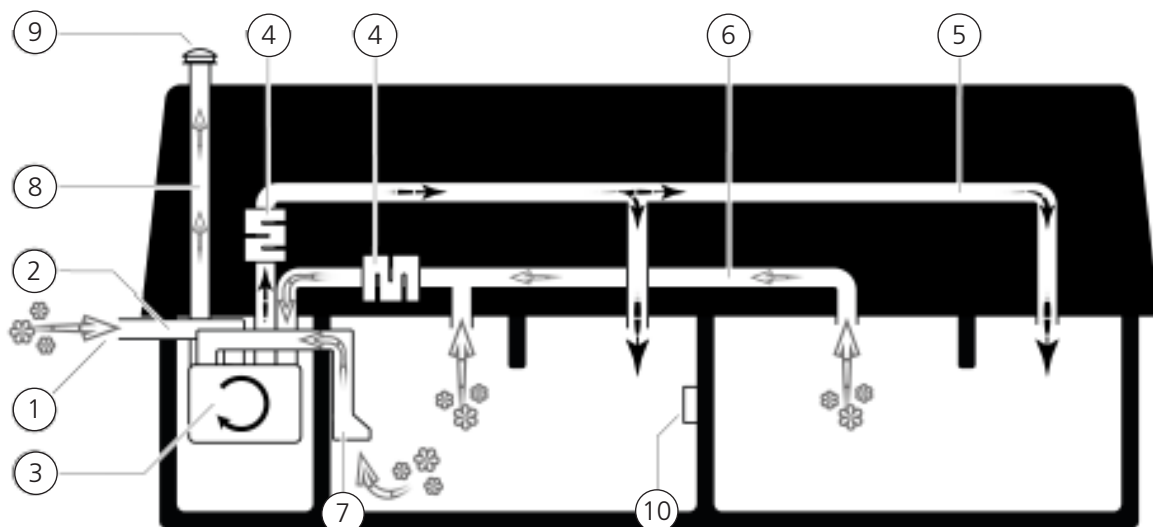

- | | |
|--------------------------------|--|
| 1. Intake grille for fresh air | 6. Extract air duct |
| 2. Fresh air duct | 7. Cooker hood extract air |
| 3. HERU T energy recovery unit | 8. Exhaust air duct |
| 4. Silencers | 9. Roof hood exhaust air |
| 5. Supply air duct | 10. IQ Control App or wireless IQC display |

3.2 Preparation and placement

When placing the ventilation unit, make sure that there is enough space to open doors and lids, to access or replace filters, fans, rotors and connections. Observe dimension (A) especially when mounting the HERU S on attics and under pitched roofs.

Dimensions (A) and (F) – view B for HERU T and view E for HERU S, show the zone that must be free to be able to service the unit. When mounting the HERU S, remember to mount the unit so that the electric connection box is facing the service aisle or such, changing the direction of flow in the unit is an option to get the junction box in the right direction.

Opposite flow direction (left) can be selected to achieve a better placement of the duct connections – see section **“3.4.6 Opposite flow direction”** page 19.

For placement of the temperature sensor in the supply air duct

– see section **“3.4.4 Install the duct sensor GT7”** page 18 and placement of bluetooth dongle

– see section **“3.4.5 Mount the Bluetooth dongle”** page 18.

See pictures and measurement instructions.

HERU T

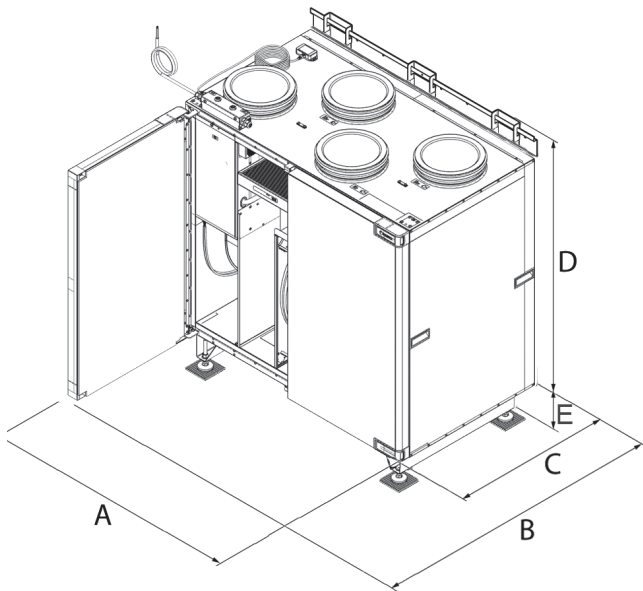

View A – Dimensional sketch.

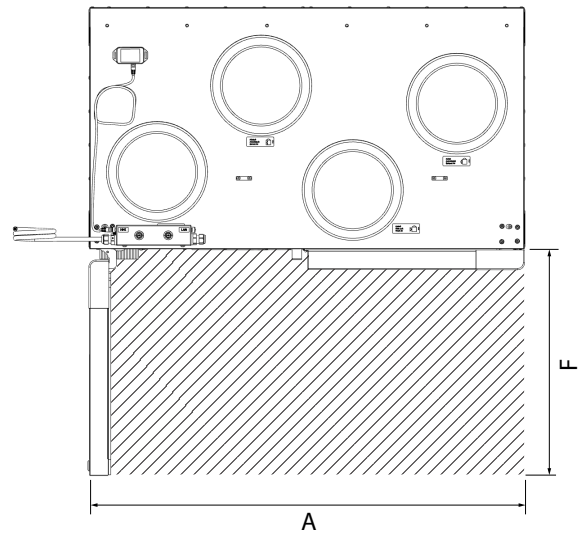

View B – Service area

Dimensions for HERU T

Model	A	B	C	D	E	F
HERU 100 T EC RE/LE	796	990	492	759	–	498
HERU 160 T EC RE/LE	942	1130	559	919	–	571
HERU 200 T EC RE/LE	1124	1344	682	1135	100	662
HERU 300 T EC RE/LE	1124	1344	682	1135	100	662



CAUTION!

The commissioning protocols must be completed for the warranty to apply. Available at the end of the manual.

HERU S

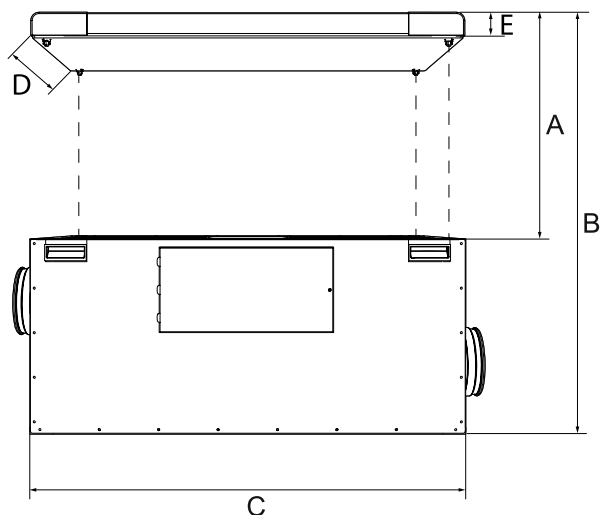

View C – Dimensional sketch.

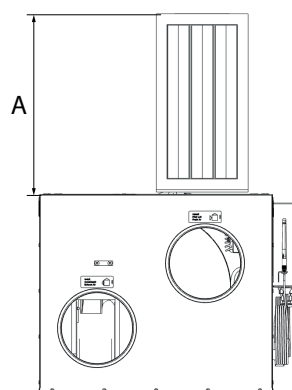

View D – Dimensions with removed filter.

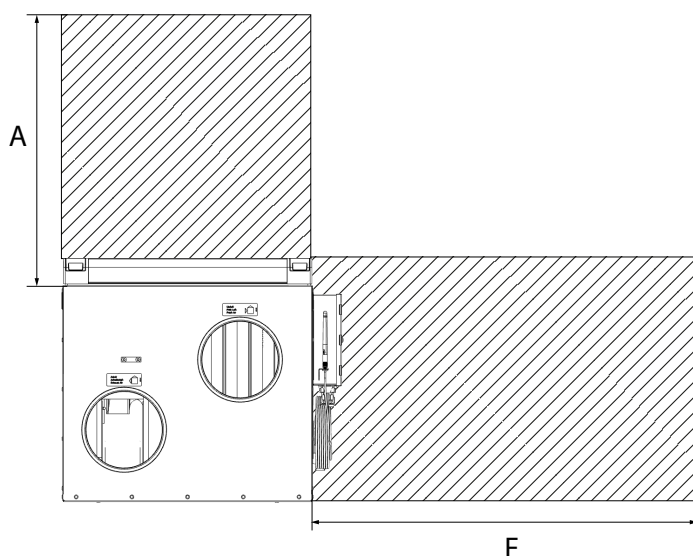

View E – Service areas.

Dimensions for HERU S

Model (mm)	A	B	C	D	E	F
HERU 100 S EC	415	850	969	507	51	1000
HERU 160 S EC	519	1038	1131	574	51	1000
HERU 200 S EC	728	1456	1250	680	51	1000
HERU 300 S EC	728	1456	1250	680	51	1000

When the unit is mounted lying on the side with the connection box facing upwards, the installation distance "F" may not be possible to follow. Make sure there is enough space for access and overview of the electric connection box. If HERU S is mounted with the electric connection box up and e.g. under pitched roof, consider there is enough space upwards to remove filters, fans and rotor.



CAUTION!

The commissioning protocols must be completed for the warranty to apply.
Available at the end of the manual.

3.3 Internet connection

Make sure that a RJ-45 LAN cable or RJ-45 WiFi dongle is available for connecting the unit to the internet (port marked LAN). This is optional, but will ensure full remote access to the unit via the app. Without internet connection, the unit can only be locally controlled via Bluetooth.

3.4 HERU S

3.4.1 Disassemble the unit to reduce the weight when installing HERU S.

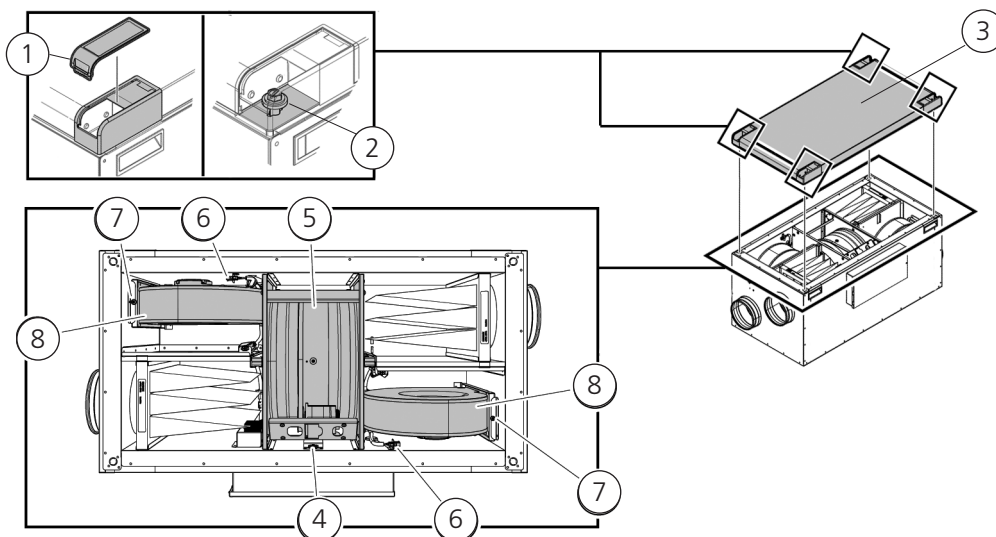

Method for dismantling unit

1. Plastic cover
2. Screws
3. Unit lid
4. Quick connector for rotor cassette
5. Rotor cassette
6. Quick connector for fan
7. Screw Torx T25
8. Fan

Tool

- Torx T25 screwdriver.
- Flat-blade screwdriver/13 mm socket .

Remove the lid of the unit.

1. Remove the plastic corner cover.
2. Unscrew the screws holding the unit lid.
3. Lift off the lid.

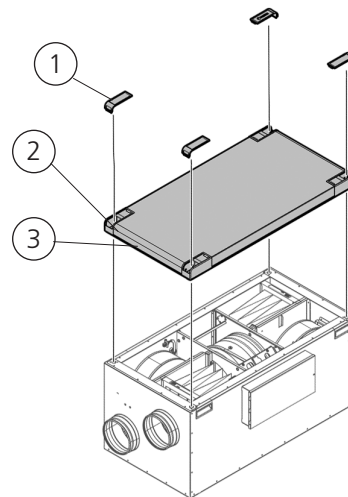
**Remove the rotor cassette.**

4. Disconnect the rotor cassette's quick connector.
5. Take out the rotor cassette.

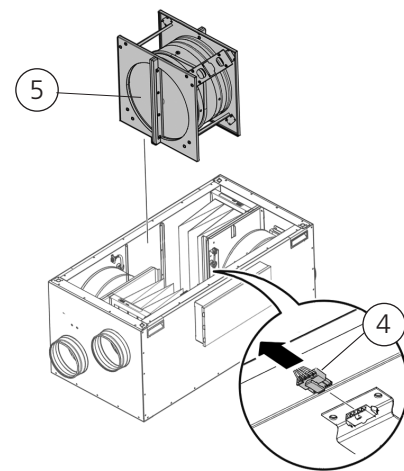
**Remove the fans.**

6. Disconnect the fans quick connectors.
7. Remove the Torx T25 screw on the fans.
8. Take out the fans.

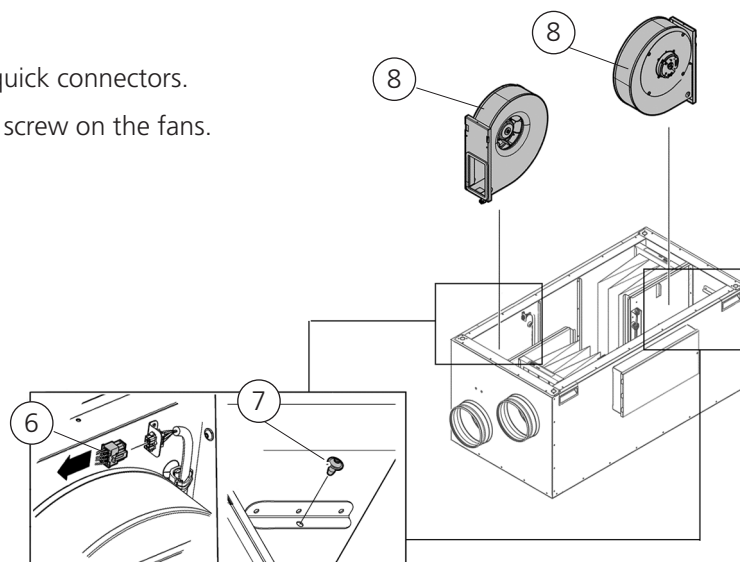

3.4.2 Installation HERU S



CAUTION!

The cooker hood must not be connected to the unit due to the increased cleaning requirement.

- Place insulation board on the installation surface.
- The dimensions, see section **"3.2 Preparation and placement"** page 12, must be followed.
- HERU S can be mounted in a cold or warm space.
- Local regulations for placing, access and electrical connections must be followed when installing HERU S.
- The dimensioned airflow should not exceed 75% of the unit's maximum capacity.
- When installing in warm and moist places, for example a bathroom or utility room, condensation may occur on the outside of the unit at low outdoor temperatures.
- If the unit is installed during cold weather and cannot immediately be put into use, the ducts must be plugged again otherwise there is a risk of condensation.
- We recommend always installing a spring-return damper in ducts for fresh air and exhaust air.
- If there are major differences between ambient temperature and the temperature in the ducts for the supply and extract air, these must be insulated to prevent condensation.
- The ducts for fresh air and exhaust air must always be insulated against condensation.
- The ducts must be insulated all the way up to the unit.

Heating coil and damper

If a heating coil is connected, a damper with spring return must be fitted to the outdoor and exhaust ducts."

Ground points for ducts

Connect the ducts to one of the external ground points (1) on the unit.

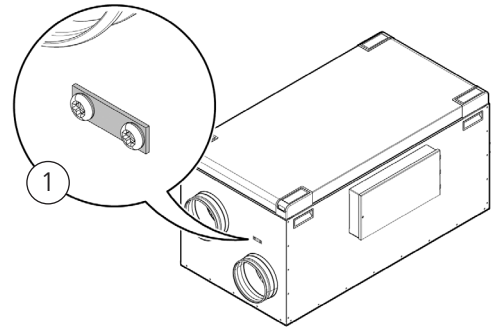

Duct insulation

All ducts should be insulated according to industry standards. The pictures show a minimum to ensure full function on the unit.

- | | | |
|----------------|----------------|-------------------------|
| 1. Outdoor air | 3. Extract air | Insulated |
| 2. Supply air | 4. Exhaust air | Condensation Insulation |



Space with outdoor temperature

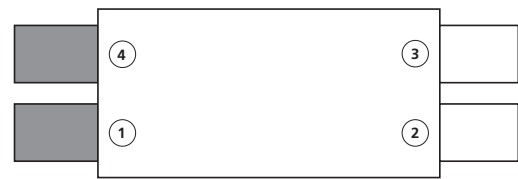

Space with indoor temperature (> 16 °C)

Tool

- Ø9 mm drill bit
- Spirit level
- Torx T25 screwdriver

Material – HERU 100 S and 160 S

- Insulation board, minimum 50 mm.
- Cable tie
- Pipe clip or flange with surrounding insulation

Material – Floor standing HERU 200 S and 300 S

- Insulation board, minimum 50 mm. Not if Floor stand is used
- Cable tie
- Floor stand (available as accessory)
- Pipe clip or flange with surrounding insulation

Placing

Installing HERU S with the lid upwards (A) or to the side (B).

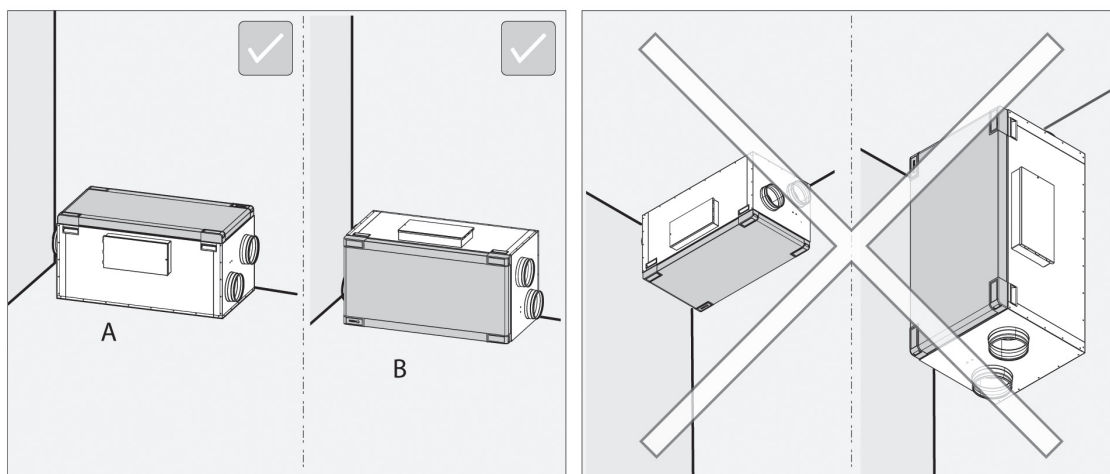

WARNING!

Do not install the unit vertically or with the cover downwards due to the risk of injury.

NOTE!

Ensure that there is space for service and maintenance around the unit.
See **"3.2 Preparation and placement" page 12**

Floor standing HERU S

Place the unit on a shock-resistant insulation board, minimum 50 mm (1).

Ensure that the unit is level in both the x and y axes. Use a spirit level.

NOTE!

The base for the unit must be level and stable.

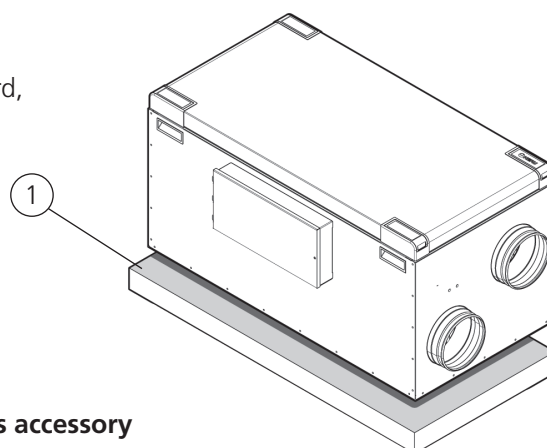

Floor standing HERU 200 S and 300 S with floor stand as accessory

Mount the floor stand with accompanying screws (3).

Ensure that the unit is level in both the x and y axes.
Use a spirit level. Adjust the feet (pos 3) if required.

NOTE!

The underlay for the unit must be even and stable.

The vibration damping mat (Novibra) (4) accessory can be placed underneath feet to reduce vibration against the floorboard.

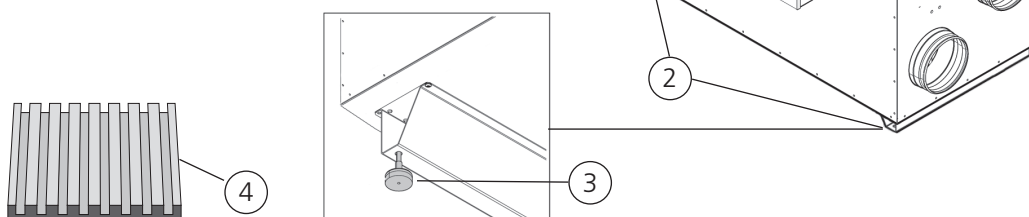

3.4.3 Connect the ducts to the unit.

Use a pipe clip or flange with surrounding insulation.

3.4.4 Install the duct sensor GT7

Mount the duct sensor GT7 in the supply air duct. See **"7 Control diagram" page 43**.

- Prepare the channel. Drill a $\varnothing 9$ mm hole, place it approximately 1000 mm after the unit, cooling or heating coil. The duct must be straight for 1000 mm before the temperature sensor, i.e. without bends and preferably at the end of a straight channel section
- Mount the duct sensor in the drilled hole. The duct sensor must be placed centrally in the duct.
- Attach the duct sensor. Secure with a cable tie around the cable bushing.

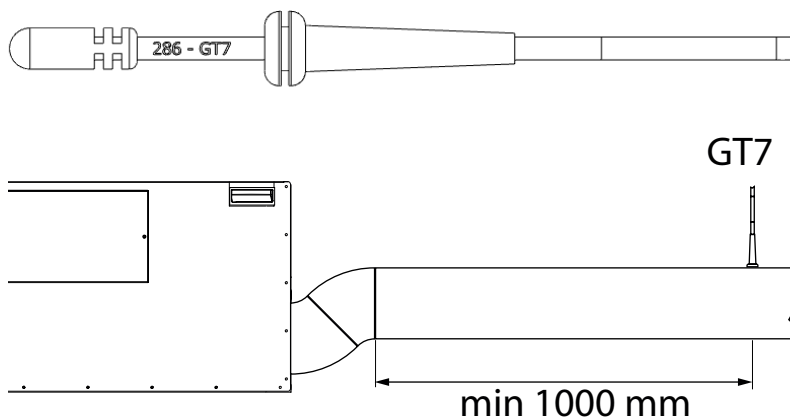

3.4.5 Mount the Bluetooth dongle

Always mount the dongle with the labelside facing the living area. The signal strength is higher in that direction, so if the dongle is mounted in e.g. the attic it should point downwards.

The dongle should be connected to the port marked HMI.

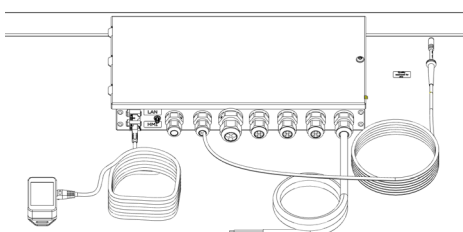
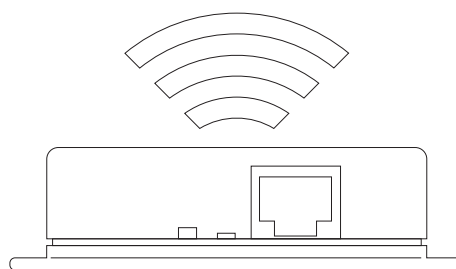

3.4.6 Opposite flow direction

NOTE!

The unit is configured for airflow in the standard direction on delivery. The electric heater must be moved if the airflow needs to be changed to the opposite direction.

Tool

- Torx T25 screwdriver.

1. Disconnect the quick connector.
2. Unscrew the screw.
3. Remove the heater from the partition.
4. Lift out the heater.
5. Move the heater to the opposite side on the other partition. Ensure that the bracket on the right side of the heater is positioned in the console.
6. Secure the heater with the screw.
7. Connect the quick connector.
8. Move the heater power supply cable in the electric connection box (8) according to the wiring diagrams. Change cable from HR2 to HL2 in the socket (9), for opposite flow direction.

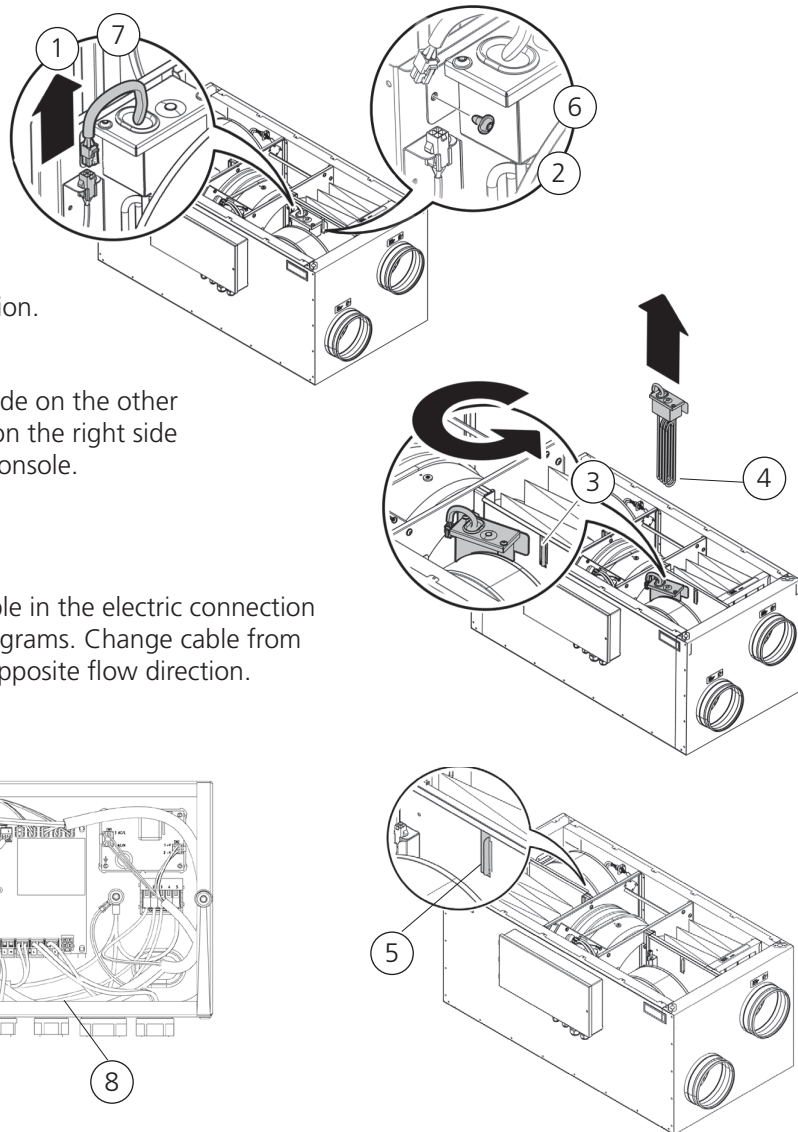

NOTE!

For more information on how to configure the unit for opposite flow direction, see **"4.7 Adapting the unit for airflow in the opposite direction" page 38.**

The duct connections in opposite flow direction.

- A. Supply air
- B. Extract air
- C. Outdoor air
- D. Exhaust air

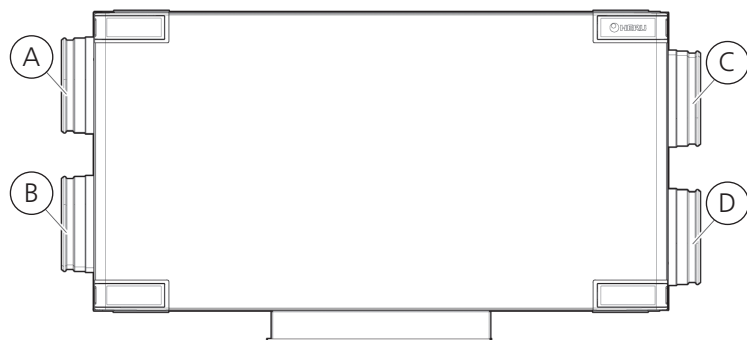

Change the labels for flow direction on the HERU S unit with four new labels from the accessory box. Place them according to the figure for opposite flow direction.

3.4.7 Mounting the parts after installing HERU S

Tool

- Torx T25 screwdriver.

Mount the fans.

1. Insert the fans.
2. Screw in the fans with the Torx T25 screws.
3. Connect the fans' quick connectors.

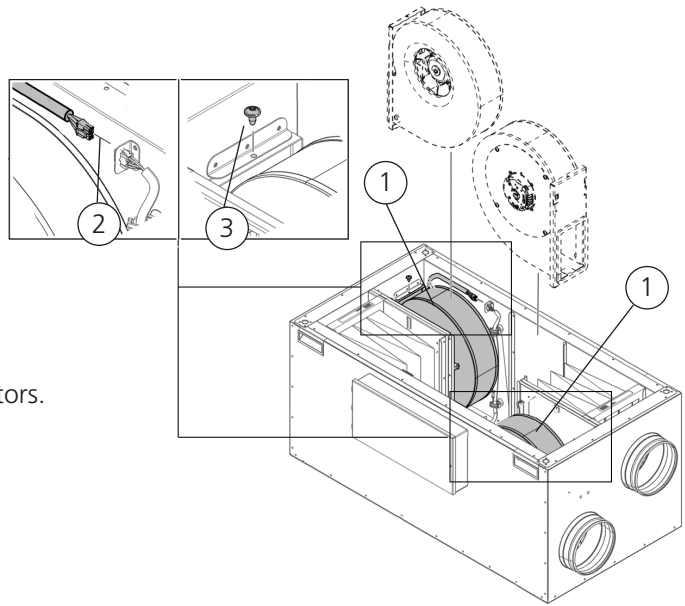

Mount the rotor cassette.

4. Insert the rotor cassette.
5. Connect the rotor cassette's quick connector.

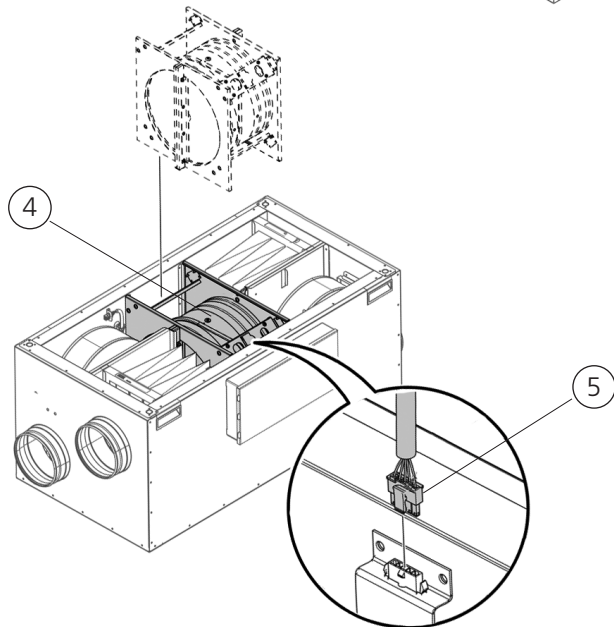

Mount the lid.

7. Place the lid on the unit.
8. Tighten the screws clockwise.
9. Click in the four plastic corner covers.

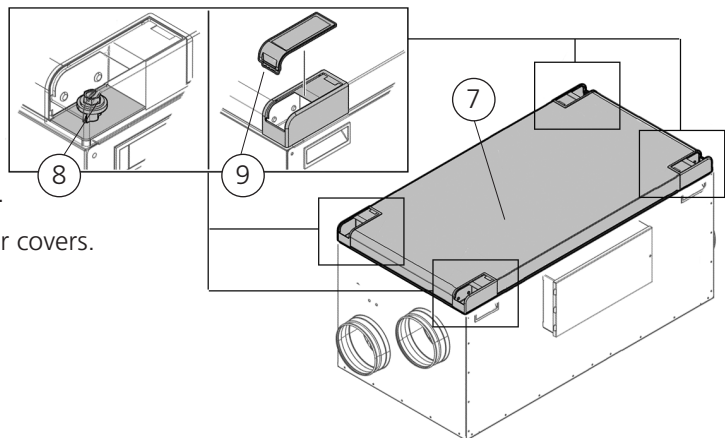

3.5 HERU T

3.5.1 Disassemble the unit to reduce the weight when installing HERU T

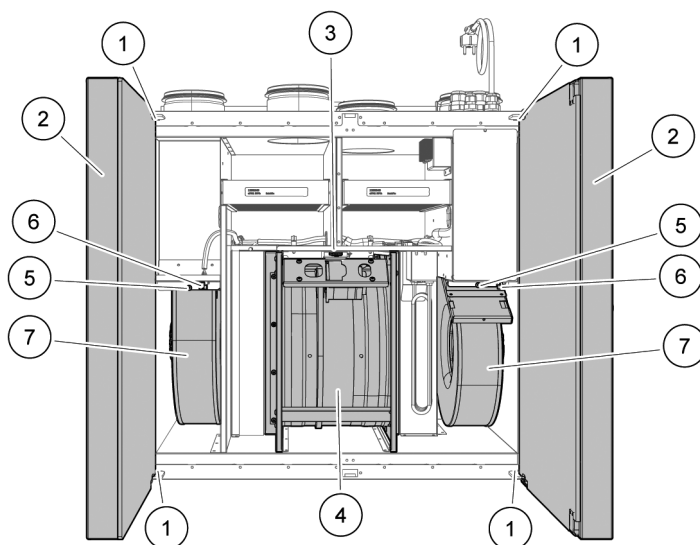

Method for dismounting unit

1. Upper and lower door screw
2. The unit's doors
3. The rotor cassette's quick connector
4. Rotor cassette
5. Torx T25 screw
6. Quick connector
7. Fans

Tool

- Torx T25 screwdriver
- Flat-blade screwdriver
- Hex key 4 mm with ball end
- Use a flathead screwdriver to open the lock on the door, Min 10x1.5 mm and Max 15x2 mm tip. The slot is 16x2.3 mm.

Dismount the unit's doors

1. Open the doors.
2. Unscrew the screws.
3. Hold the door and remove the upper and lower screws.

Pull the door outwards (1) to release it from the unit.

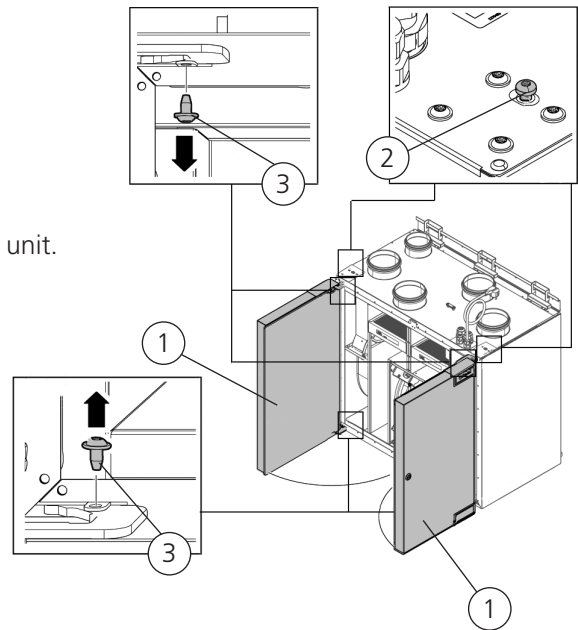

Remove the rotor cassette.

4. Remove the rotor cassette's quick connector.
5. Pull out the rotor cassette.

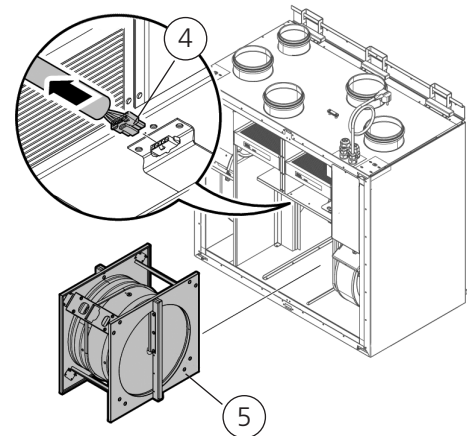

Remove the fans.

6. Remove the quick connectors for the fans.
7. Unscrew the Torx T25 screws on the fans.
8. Pull out the fans.

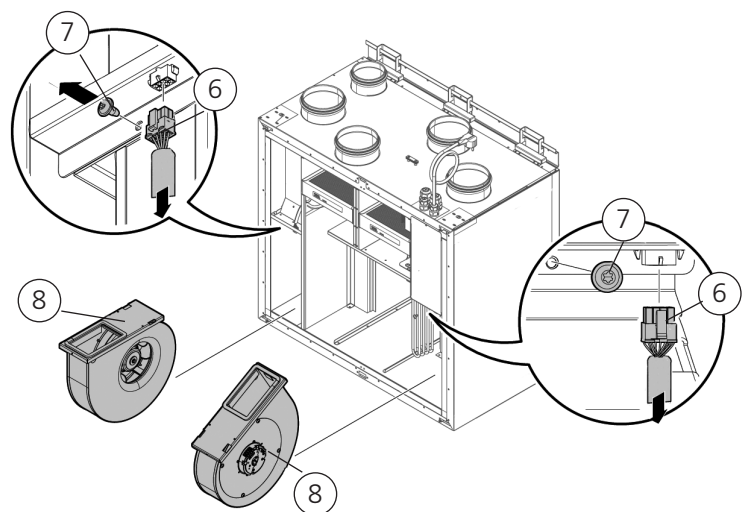

3.5.2 Installation HERU T

- The mounting distance, see “3.2 Preparation and placement” page 12, must be followed.
 - HERU T can be mounted in a cold or warm space.
 - Local regulations for placing, access and electrical connections must be followed when installing HERU T.
 - The dimensioned airflow should not exceed 75% of the unit’s maximum capacity.
 - When installing in warm and moist places, for example a bathroom or utility room, condensation may occur on the outside of the unit at low outdoor temperatures. If the unit is installed during cold weather and cannot immediately be put into use, the ducts must be plugged again otherwise there is a risk of condensation.
 - If there are major differences between ambient temperature and the temperature in the ducts for the supply and extract air, these must be insulated to prevent condensation.
 - The ducts for fresh air and exhaust air must always be insulated against condensation.
 - The ducts must be insulated all the way up to the unit.
- No other preparations are required.

Tool

- Spirit level.
- Screwdriver Torx T25.

Heating coil and damper

If a heating coil is connected, a damper with spring return must be fitted to the outdoor and exhaust ducts.”

Ground points for ducts

Connect the ducts to one of the external ground points (1) on the unit.

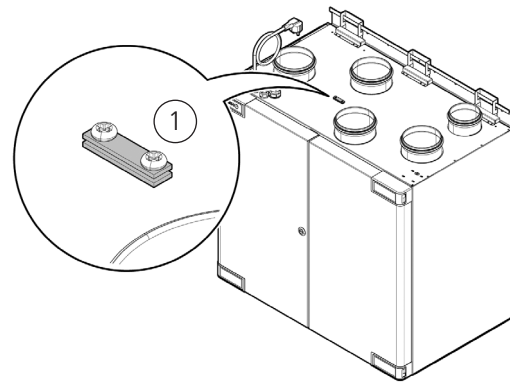

Duct insulation

All ducts should be insulated according to industry standards. The pictures show a minimum to ensure full function on the unit.

- | | |
|----------------|----------------|
| 1. Outdoor air | 3. Extract air |
| 2. Supply air | 4. Exhaust air |

-  Insulated
 Condensation insulated

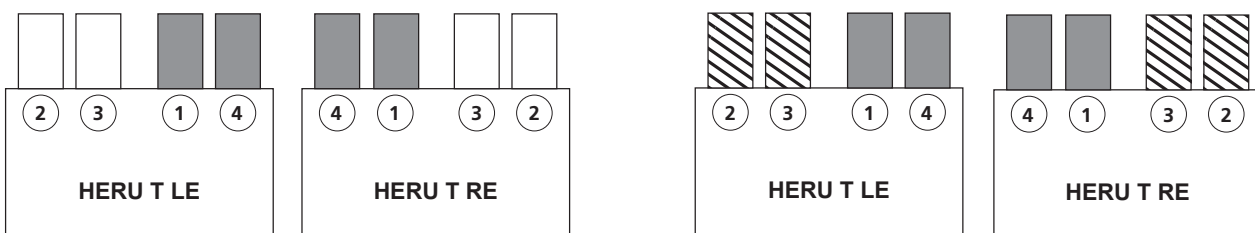

Space with indoor temperature (>16° C)

Space with outdoor temperature

Material - wall mounted HERU 100 and 160 T

- Fastener that is suitable for the construction and condition of the wall.
- Pipe clip or flange with surrounding insulation.

Material - floor standing HERU 160 T

- Floor stand (available as accessory).
- Pipe clip or flange with surrounding insulation.

Material – Floor standing HERU 200 T and 300 T

- Pipe clip or flange with surrounding insulation.

Wall mounted HERU 100 T and 160 T

1. Install HERU T with the duct connections upwards (A) or to the side with the doors upwards (B).

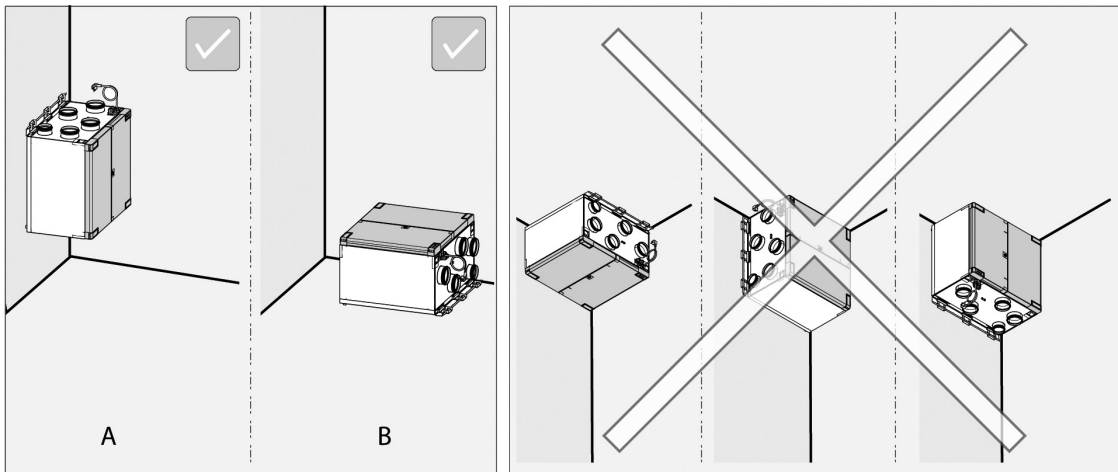
**WARNING!**

Do not install the unit with the duct connections or the doors down toward the ground due to the risk of injury.

**CAUTION**

The unit must be mounted on an insulated wall. Avoid walls to bedrooms.

NOTE!

Ensure that there is space for service and maintenance. See **"3.2 Preparation and placement"** page 12.

2. Secure the self-adhesive rubber pads in the rear lower corner with one rubber pad in each lower corner (HERU 100 T, 160 T) and one in the middle (HERU 160 T).

3. Remove the screws (3 for HERU 100 T, 4 for HERU 160 T) and remove the wall console from the HERU unit.

4. Secure the wall console horizontally on the insulated wall with the correct number and type of fastener. The screw hole in the wall console must be positioned 27 mm above the top of the unit.

5. Angle the lower section of the unit away from the wall, suspend the unit on the console and allow the unit's lower section to fall back against the wall.

6. Adjust the unit sideways to achieve the correct position.

7. Ensure that the self-adhesive rubber pads have good contact with the wall.

8. Secure the unit on the wall console with the accompanying screws (3 screws for HERU 100 T and 4 screws for HERU 160 T).

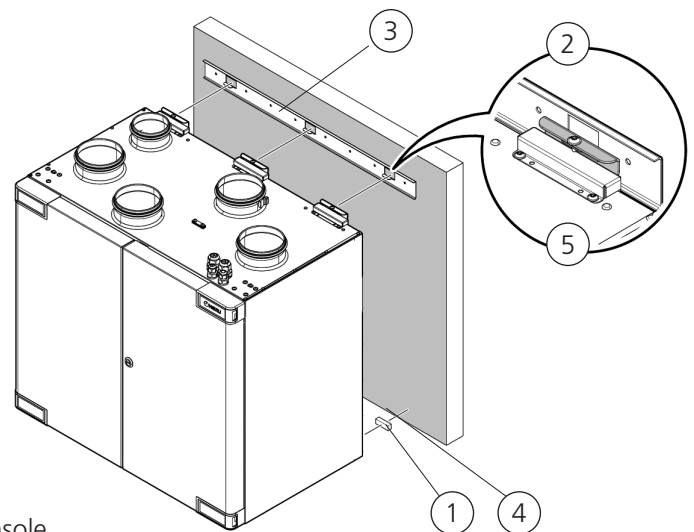

Floor standing HERU 160 T with floor stand as an accessory

NOTE!

The base for the unit must be level and stable.

NOTE!

The Novibra mat accessory can be placed under the feet to minimise vibrations from the floor joists.

1. Mount the floor stand with accompanying screws.
2. Ensure that the unit is level in both the x and y axes.
Use a spirit level.
Adjust the feet if required.

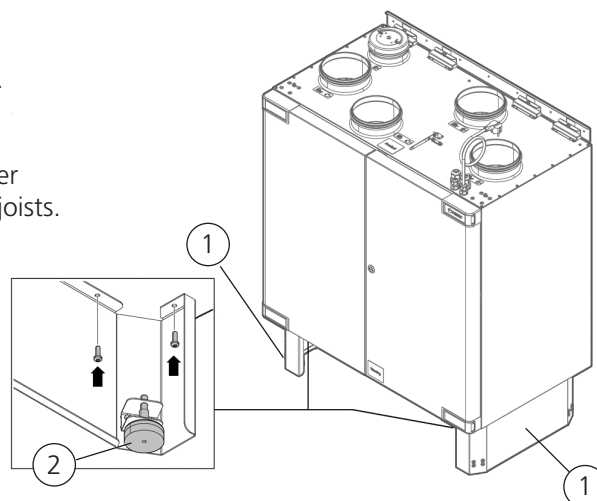

Floor standing HERU 200 and 300 T with floor stand included

NOTE!

The base for the unit must be level and stable.

NOTE!

The Novibra mat accessory can be placed under the feet to minimise vibrations from the floor joists.

1. Ensure that the unit is level in both the x and y axes.
Use a spirit level.
Adjust the feet if required.

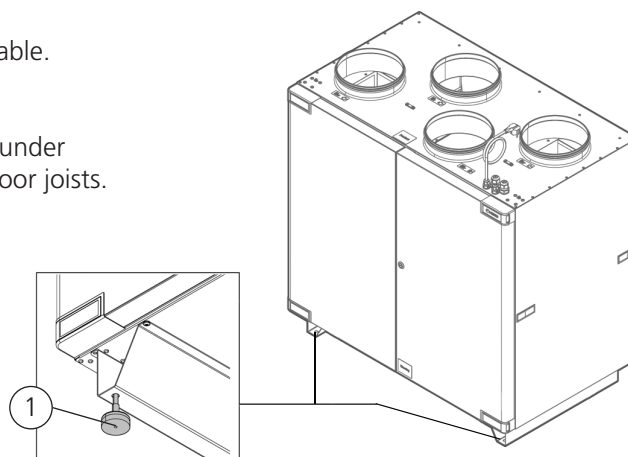

3.5.3 Cooker hood

HERU 100 and 160 T are equipped with a cooker hood connection as standard, where the air from the cooker hood does not pass through a filter or the rotating heat exchanger. When activating the cooker hood, the HERU unit's pre-set boost mode is started and creates extraction from the cooker hood.

The cooker hood must be:

- Equipped with a tight-closing dampers. The cooker hood does NOT have an integrated fan.
- Connected into the unit via a dual-core, 0.75 mm² cable.
- Equipped with a voltage free contact that completes the circuit when the cooker hood is activated.

If a cooker hood is to be connected to the system, the insulated cover must be dismantled from the cooker hood connection, and a duct from the cooker hood mounted instead.

**WARNING!**

Ensure that the installation fulfils local and national fire safety requirements.

**CAUTION!**

A cooker hood connected to HERU T must not have an integrated fan.

**CAUTION!**

A cooker hood must NOT be connected to HERU 200 and 300 T.

1. Fit the cooker hood according to the manufacturer's instructions.
2. Connect a two-wire cable from the cooker hood to the HERU unit. Connect the cable through one of the free cable entries in the top of the unit. Loosen the nut on the cable gland and remove one of the bushing plugs.
3. Pull through the appropriate length of cable for connection on the control board.
4. Pull out the removable terminal block at position D2 on the control board and connect the cable from the cooker hood to the terminal block.
5. Then push the terminal back to its position D2 on the control board.
6. Connect the duct from the cooker hood to the unit. Remove the insulated cover on the top of the unit and connect the duct from the cooker hood to the unit's connected, labelled cooker hood.

3.5.4 Connect the ducts to the unit.

Use a pipe clip or flange with surrounding insulation.

3.5.5 Mount the Bluetooth dongle

Always mount the dongle with the label side facing the living area. The signal strength is higher in that direction, so if the dongle is mounted in e.g. the attic it should point downwards. The dongle should be connected to the port marked HMI.

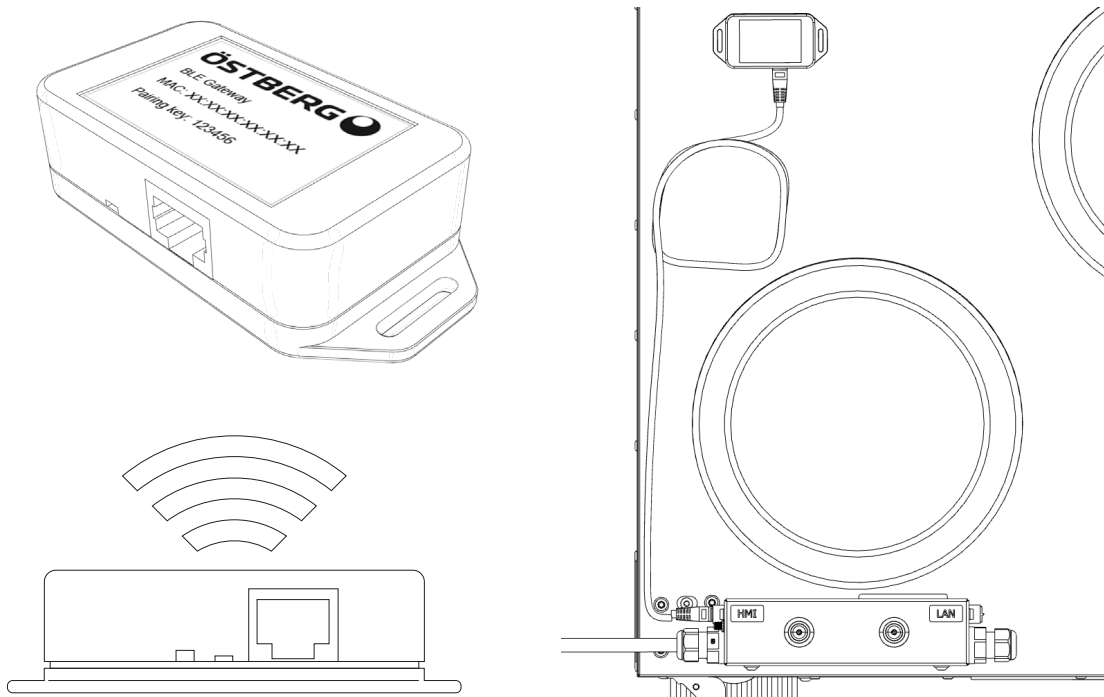

3.5.6 Mounting the parts after installing HERU T

Tool

- Torx T25 screwdriver
- Hex key 4 mm with ball end

Mount the fans.

1. Insert the fans.
2. Screw tight the Torx T25 screws on fans.
3. Connect the fans' quick connectors.

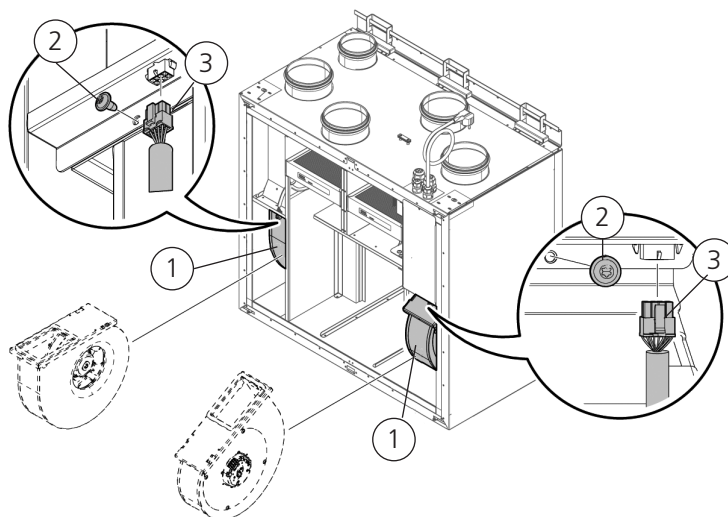

Mount the rotor cassette.

4. Slide in the rotor cassette in the unit.
5. Connect the rotor cassette's quick connector.

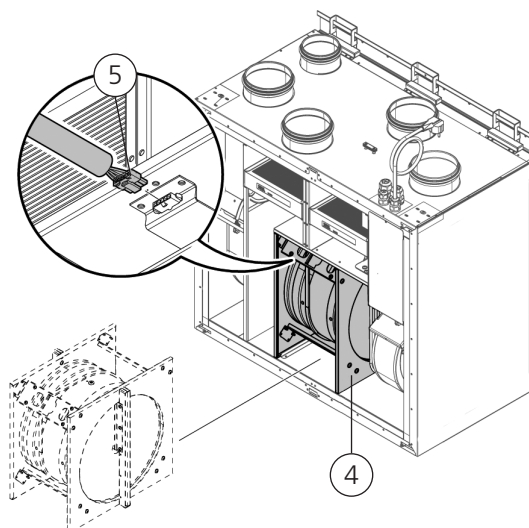

Mount the doors.

6. Secure the doors on the unit.
7. Press in the door hinges into the hinge brackets.

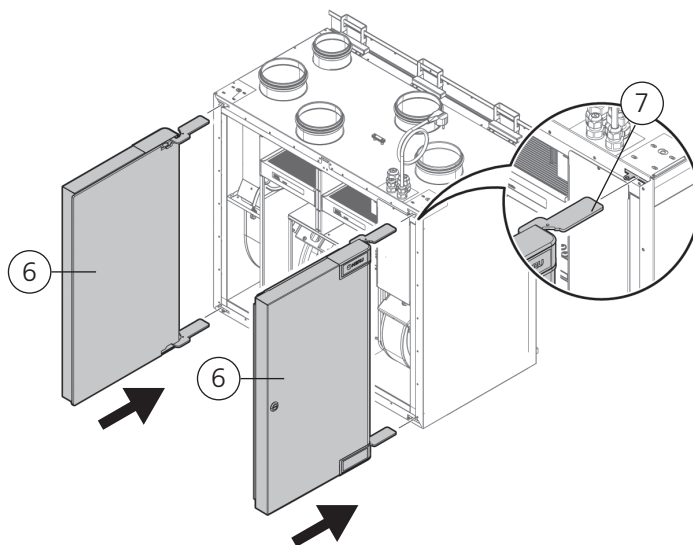

8. Hold the doors, and screw in the upper and lower screws.
9. Then screw the locking screws.

Close the doors.

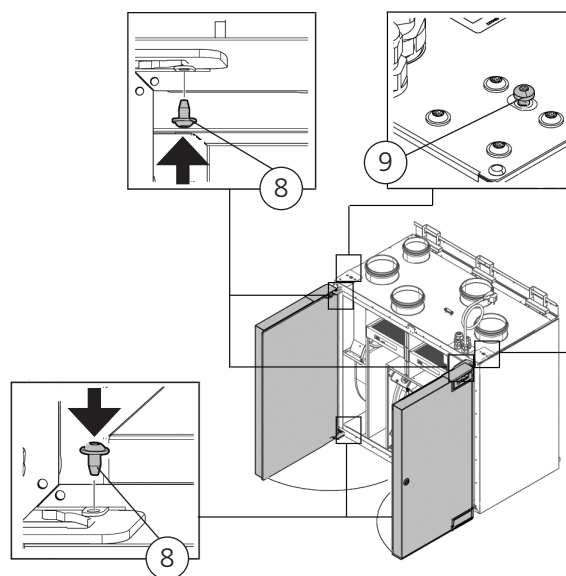

3.6 Connecting the unit to the power source



WARNING!

The unit must always be equipped with a type A or B, 30 mA residual current device (RCD). Units without plugs must be installed with a safety switch, which must be mounted close by.



WARNING!

Units with plugs must be fused with a C10 A fuse.



WARNING!

Units without plugs must be fused with a 2x10 A fuse together with a 2,5 mm² conductor.



WARNING!

All electrical installations must be performed by a qualified electrician.



WARNING!

The safety switch must not be used for normal starting and stopping of the unit. Use the IQ Control App.



WARNING!

Check that the power cable is not damaged during mounting and installation.



WARNING!

All operations on the unit and its peripheral equipment must be performed in accordance with local laws and regulations.



WARNING!

Ensure that there are no loose parts inside the unit and that the doors are closed and locked before turning on the power.

3.7 Connecting Modbus to external control equipment

- The external control equipment must support Modbus RTU data protocol, which is used for RS485 and TCP/IP in order to communicate with the unit. For TCP/IP use the LAN-port.

Tool

- Torx T 25 screwdriver
- Flat-blade screwdriver (only HERU T)

Connecting Modbus to HERU S:

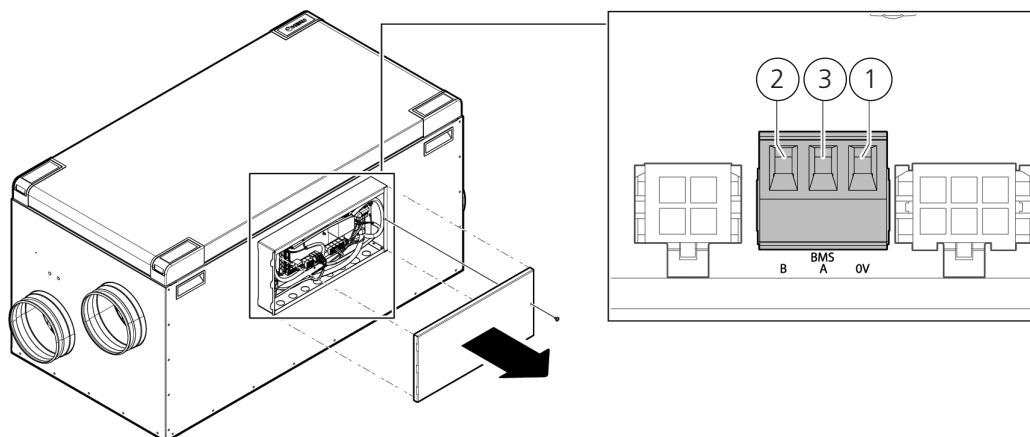

Connecting Modbus to HERU T:

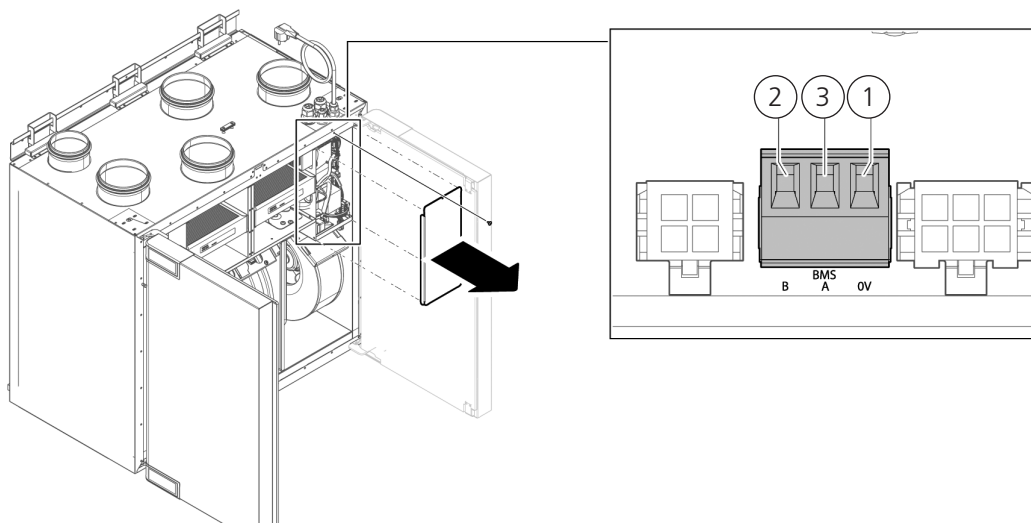

1. Connect GND to 0.



CAUTION!

If conductor is connected to terminal 0 and voltage potential is present, it will damage the equipment

2. Connect Rx-/Tx- to B.
3. Connect Rx+/Tx+ to A.

NOTE!

For more information on how to configure Modbus via the IQ Control App, see **"4.8 Configuring the unit for Modbus" page 38**.

3.8 Final routines

1. Ensure that there are no loose parts inside the unit and that the lid/doors of the unit are closed and locked.
2. Ensure that the product is operating and no alarm is active.
3. Pick up all the tools.
4. Notify relevant persons that the work is complete.
5. Follow the routines for returning and disposing of replaced parts and packaging material.
6. Fill in the relevant points in the commissioning protocol, the protocol can be found at the end of the manual.

4 Commissioning



WARNING!

The unit's ducts must be connected, hatches/doors closed and screws tightened before starting the unit to avoid the risk of personal injury from rotating parts.



WARNING!

Filters must be installed before using the unit.



CAUTION!

The commissioning protocol must be completed for the warranty to apply. Found at the end of the manual.

For information about active view in the IQ Control App, press the **i-button**.

4.1 Install the HERU IQ app

The **HERU IQ app** is available for free download in both the **Appstore** and **Google play**. With the app, you have full functionality for controlling your unit both via Cloud and via Bluetooth (requires IQC Bluetooth module). On first launch of the app, one is asked to allow HERU IQ to find and connect nearby devices. This condition must be allowed for the app to find and connect to the IQC Bluetooth module.

APPSTORE



GOOGLE PLAY



4.1.1 Create new account

To use the app, you need to create an account. See the following steps to create a new user:

1. Open the HERU IQ app and click Register.
2. Create a new user:
Enter email address and accept the terms of use.
View A
3. A verification email from iqcloud@ostberg.com will be sent to the selected email address. Choose a password and enter the verification code.
Click CONFIRM. View B
4. The account is now created and you can start log in.

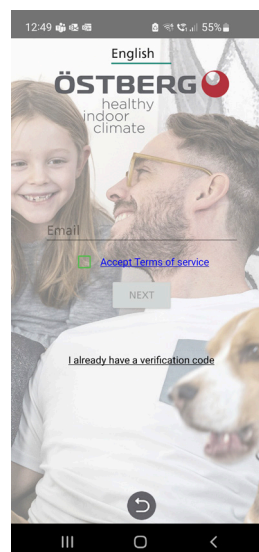

View A

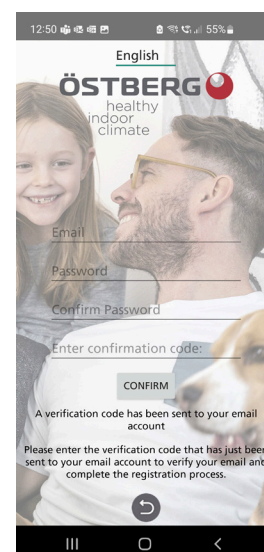

View B

4.1.2 Delete user

Use the menu to remove an active user and when changing users. View D.

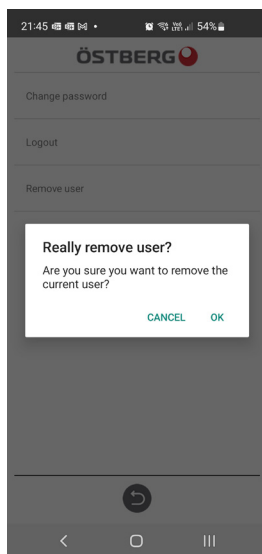

View D

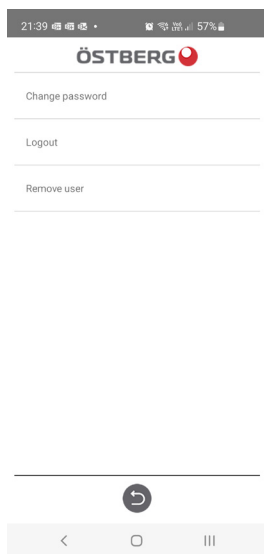

View E

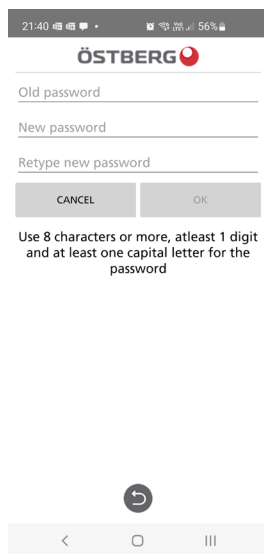

View F

4.1.3 Change Password

If you want to change your current password, this is done under the Settings tab and then under the Users menu. Click Change Password. View E. Enter the current password in the field, then enter the desired password. View F.

4.1.4 Forgot password

If you have forgotten your password, you can reset it in the app. This is done by:

1. In the app, click Forgot password. View G
2. Enter the email address. A verification code will be sent to the specified email address. View H
3. Enter the verification code in the field. View I
4. A new password has now been created and you can thus log in.

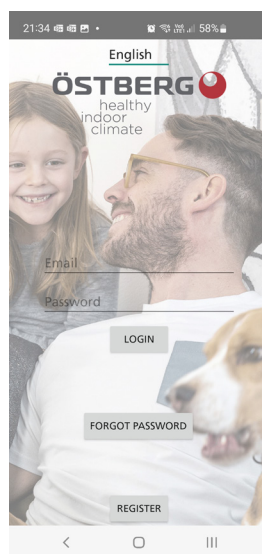

View G

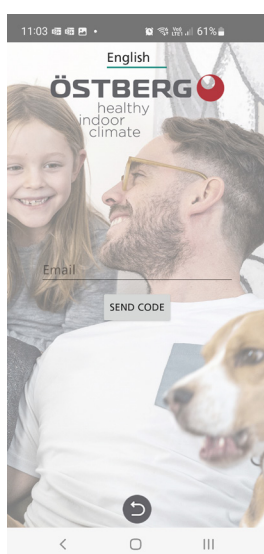

View H

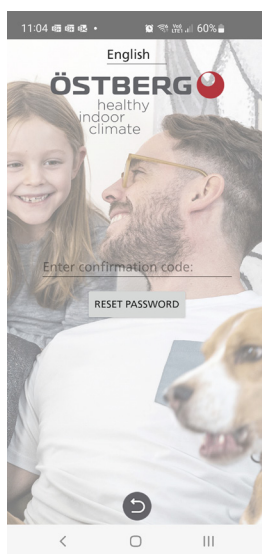

View I

4.2 Connection via IQC Bluetooth module

Via the IQC Bluetooth module, you are given the opportunity to control your unit via Bluetooth. However, only 1 person can be connected to the IQC Bluetooth module and control the unit at a time. The IQC Bluetooth module is connected to the HMI port on the control board and is already connected from the factory. To control the unit via the IQC Bluetooth module, go through the following steps below or read the guide in the app. The guide is found under the Devices tab and then under **PAIR NEW HERU**.



View J

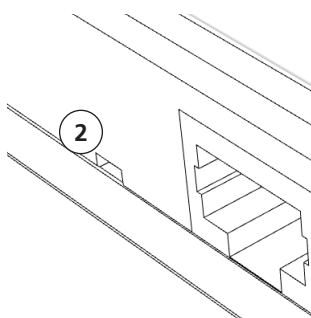

View K

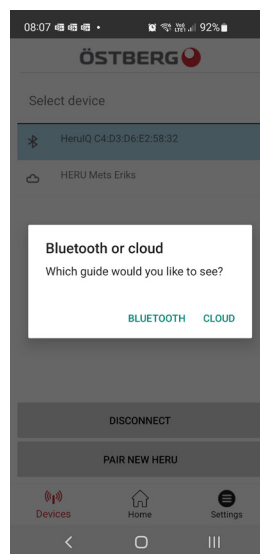

View L

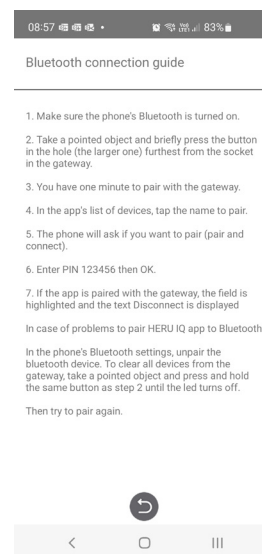

View M

1. Power up the unit via the plug.
2. Make sure Bluetooth is turned on in your phone.
3. Open the HERU IQ app and log in.
4. Go to the devices tab.
5. The IQC Bluetooth module (1) will now be in the list and displayed with the name HeruIQ + its Mac address. The Mac address can be found on the label on the IQC Bluetooth module. View J.
6. On the IQC Bluetooth module, click the pairing button (2) with a narrow object such as a paperclip. The LED lamp now lights up blue for 60s, which means that the IQC Bluetooth module is in pairing mode. View K.
7. In the app, select the IQC Bluetooth module from the list. A pop up box now appears where you are asked to enter the pairing key. View L&M.
8. Enter the pairing key 123456 and click pair. The pairing key can be found on the label on the IQC Bluetooth module.
9. Pairing is now complete. This can be verified by a blue field appearing over the IQC Bluetooth module in the list and that you also have the option of being able to disconnect from the device. Under the home screen, a Bluetooth symbol should also appear at the top of the left status bar.

4.2.1 Reset of IQC Bluetooth module

If the IQC Bluetooth module needs to be reset, this is done by holding down the pairing button (2) for 5s. The LED light will then go out and all paired phones that have been paired to the IQC Bluetooth module will disappear from the memory. If you want to pair with the IQC Bluetooth module again, repeat the same steps as in section 4.2. View K.

ATTENTION! The IQC Bluetooth module must be removed in the phone under Bluetooth settings before trying to pair again after a reset.

4.3 Connection via Cloud

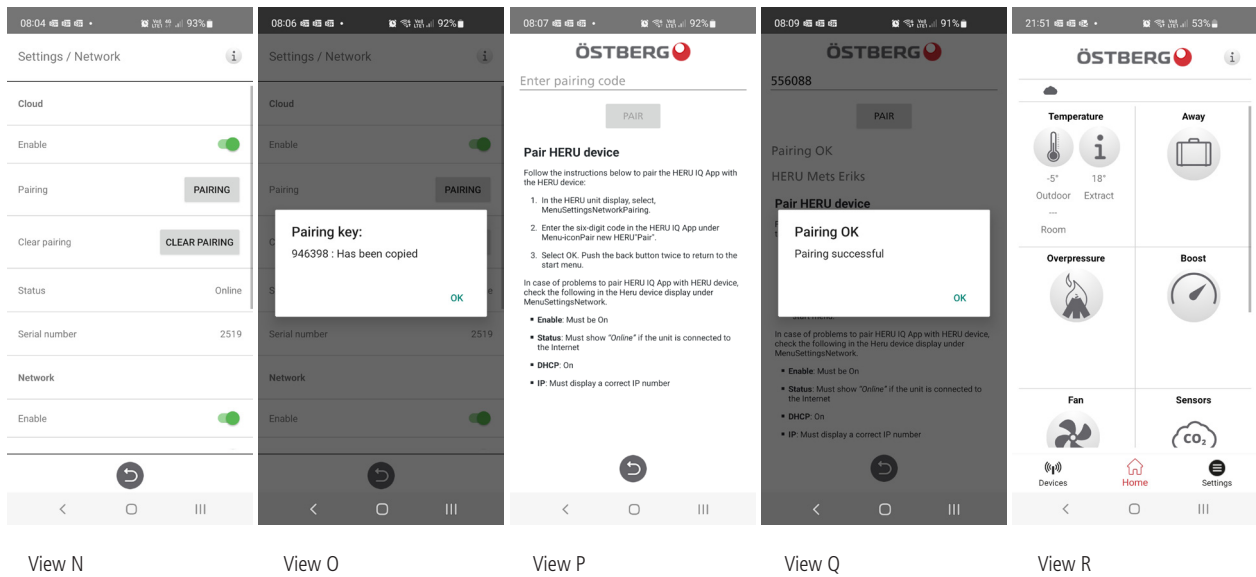

Regardless of whether you have a display or an IQC Bluetooth module, you can also connect your unit to the Cloud. However, it is required that you have internet for your unit. To connect your unit via the cloud, start by:

1. Connect the unit to the internet via the LAN port on the control board.
2. Go to the Settings tab and then go under Network.
3. Activate the toggle both for network and Cloud. Make sure the status is Online. View N.
4. Get a pairing key by clicking pairing. The pairing key is automatically copied. View N&O.
5. Then back out of the menu and go to the Devices tab.
6. Click PAIR NEW HERU. A pop up message will then appear, then select Cloud.
7. Click on the Enter pairing code field and click once more to get the option to directly paste the downloaded pairing key. View P.
8. Then click Pair. A confirmation that the pairing is okay will be given via a pop up message. Click OK. View P.
9. Under the Devices tab there is now a cloud icon named HERU. View R.
10. Select HERU to connect the unit via Cloud. Under the home screen, no Bluetooth symbol is now visible because the unit is connected via Cloud.

4.3.1 Remove unit from Cloud

If you have previously paired an unit with the Cloud and want to remove it, you can do so under the Settings tab then under the Cloud settings menu. See steps below.

1. Go to the Settings tab and then into the Cloud settings menu.
2. Under Select HERE, select the unit to be removed from the Cloud.
3. Then click on Save aggregate. View S.
4. The unit is now deleted from the Cloud and will be removed from the list under the Devices tab. However, it is not until after the app is closed and opened again that the unit via Cloud disappears from the list.

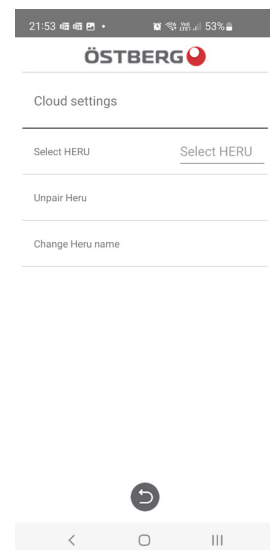

View S

4.4 Updating software

If the unit needs to be updated to a later software, you can proceed in different ways, either you update the unit via an Android phone, PC or via a MAC computer. Be aware that an update cannot take place via an iPhone regardless of model. Also keep in mind that if an update takes place via a computer, the computer must have Bluetooth capability. If the computer lacks Bluetooth, Bluetooth adapters are available for purchase. Minimum requirement is USB 4.0. Go to the respective section for the selected update method

4.4.1 Update via an Android phone

The unit is updated using the IQC Bluetooth module. It is therefore not possible to update the unit via the Cloud. See the following steps for updating via an Android phone.

1. Go to ostberg.com/update on your phone and download the update file. The file consists of a Zip file.
2. Log in to the HERU IQ app and then go to the Settings tab.
3. Under the settings tab, go to the Firmware update menu.
4. Click Select FIRMWARE .ZIP and select the downloaded update file.
5. The update file "heruiq_master_xx.ZIP" is now at the top of the menu.
6. Then click UPLOAD FIRMWARE. The update process will now begin. The process is visible both in the app and in the phone's status bar.
7. When the update process is complete, the app will say "Upload complete" and the phone's status bar will say **"Upload successful, device will restart"**.

4.4.2 Update via PC

The update via PC requires that you have access to Bluetooth because you need to connect to the IQC Bluetooth module. See the following steps for updating via a PC computer.

1. Download HeruIQ FWupdate updater on Microsoft store.
2. Then go to ostberg.com/update and download the update file, heruiq.zip.
3. Open the program HeruIQ FWupdate.
4. Under the Find Device tab, click Start searching. HeruIQ FWupdate will now start searching for available IQC Bluetooth modules that are available. Available IQC Bluetooth modules then appear in the list with the name HeruIQ and its Mac address. The Mac address can be found on the label on the IQC Bluetooth module.
5. On the IQC Bluetooth module, click the pairing button with a narrow object such as a paper clip. The LED lamp now lights up blue for 60s, which means that the IQC Bluetooth module is in pairing mode.
6. In HeruIQ FWupdate, click on selected IQC Bluetooth module in the list and then click on Pair new device. A pop up message will then appear for entering the pairing key.
7. In the field, enter the pairing key **123456** and click Allow. The message that the connection was successful will then be given. The pairing key can be found on the label on the IQC Bluetooth module
8. Then go to the Connect & Update tab and click Connect. The status will then change to Connected and in the field below it will say Device connected.
9. Then click on Select file and select the update file, heruiq.zip. The update will then begin.
10. When the update is complete, the status will change to Upload completed.

4.4.3 Update via MAC

The update via a MAC computer requires that you have access to Bluetooth because you need to connect to the IQC Bluetooth module. See the following steps for updating via a MAC computer.

1. Download the update program HeruIQ FWupdate on the App store.
2. Then go to ostberg.com/update and download the update file, heruiq.zip.
3. Open the program HeruIQ FWupdate.
4. Under the Devices tab, available IQC Bluetooth modules appear with the name HeruIQ and its Mac address. The Mac address can be found on the label on the IQC Bluetooth module.
5. On the IQC Bluetooth module, click the pairing button with a narrow object such as a paper clip. The LED lamp now lights up blue for 60s, which means that the IQC Bluetooth module is in pairing mode.
6. In HeruIQ FWupdate click on selected IQC Bluetooth module in the list. The Connect device tab will then appear.
7. Click on Connect device. Now the Pair Device tab appears.
8. Next, click on Pair Device. A pop up message will then be given where you are asked to enter the pairing key.
9. In the field, enter the pairing key **123456** and click Allow. The message that the connection was successful will then be given. The pairing key can be found on the label on the IQC Bluetooth module
10. Then click on Select file and select the update file, heruiq.zip. The update will then begin.
11. The upload will thus begin and when the upload is complete a pop up notice will be given that says **"Firmware update successful. Device will restart now."**

4.5 First start-up of the HERU unit

1. Power up the HERU unit.
 - If the unit has a plug, connect it to an outlet.
 - If the unit does not have a plug, turn on the power with the safety switch.
2. Pair bluetooth using the app.
3. Go to Settings and then tap "Start Device > OK". The device starts for the first time with a start sequence that takes about 15 min. View T.

NOTE!

The device will not respond to any command until the boot sequence is complete.

4. When the boot sequence is complete, the device operates according to the preset values.



4.5.1 Update software in ventilation units

The firmware can be updated from:

1. IQ Control App – Android via Bluetooth
2. A PC/MAC computer via Bluetooth.
3. An IQC monitor (accessory).

If there is a message that there is an updated firmware, follow the instructions in the IQ app.

4.6 Configuring the unit

Prepare the configuration by having values for the following parameters at hand:

- Type of heater
- **Heater**, choose **Electric**. **Water** is a possible choice if a external heating coil is installed.
- Desired control method
- Maximum limit for temperature reference value
- Temperature limits for supply air
- Heat retention temperature and limits for freeze protection
- For **Switch input contact function**: if normally open (NO) or normally closed (NC) for:
 - Fire alarm**
 - Pump alarm**
 - Boost**
 - Overpressure**
 - Extended operation**
 - Away mode**
 - Filter**
- The switch's input signal types for **Boost**, **Away** and **Extended operation**.
- **Alarm class**: A or B.
- **Warnings alarm relay**: on/off.
- **Flow direction**
- **Standard fan speed** for **Supply air** and **Extract air**
- **Minimum fan speed** for **Supply air** and **Extract air**
- **Maximum fan speed** for **Supply air** and **Extract air**
- **Filter control: Timer**

1. Open the main menu, select **Service**.
2. Log in. Enter code 1991.
3. Select **Setup Wizard**.
4. Click **OK** in the dialogue box that is displayed.
5. Follow the wizard to set all settings.
6. Click on the button **Finished**.
7. Return to the start screen.

4.7 Adapting the unit for airflow in the opposite direction

- HERU S only: The electric heater must be mounted for flow in the opposite direction. No other preparations are required.

1. Open the main menu, select **Service**.
2. Log in. Enter code 1991.
3. Select **Fan regulation**.
4. Click **OK** in the dialogue box that is displayed.
5. In the alternative **Flow** select **Opposite**.
6. Return to the start screen.

4.8 Configuring the unit for Modbus

4.8.1 Configuring the unit for Modbus via RS485

ID and baud rate must be configured to comply with the Modbus Network.
Download the complete Modbus register here: <https://www.ostberg.com>.

Open the main menu, select **[Service]**.

Log in Enter code **[1991]**.

Select **[Communication]**.

For the [Modbus] type select **[RS485]** and enter the following values:

Address:

Baud:

Stop bit:

Parity:

Return to the start screen.

4.8.2 Configuring the unit for Modbus with TCP/IP

For Modbus over TCP/IP to work, the unit's network settings must be configured first.
Download the complete Modbus register here: <https://www.ostberg.com>.

Open the main menu, select **[Service]**.

Log in Enter code **[1991]**.

Select **[Communication]**.

For the **[Modbus]** type select **[TCP/IP]** and enter desired value.

Port: 502 (default)

Return to the start screen.

Make sure that **[Network]** is activated to enable communication over TCP/IP.

Activate **[DHCP]** to automatically assign IP address and DNS server dynamically from the network

5 Technical data

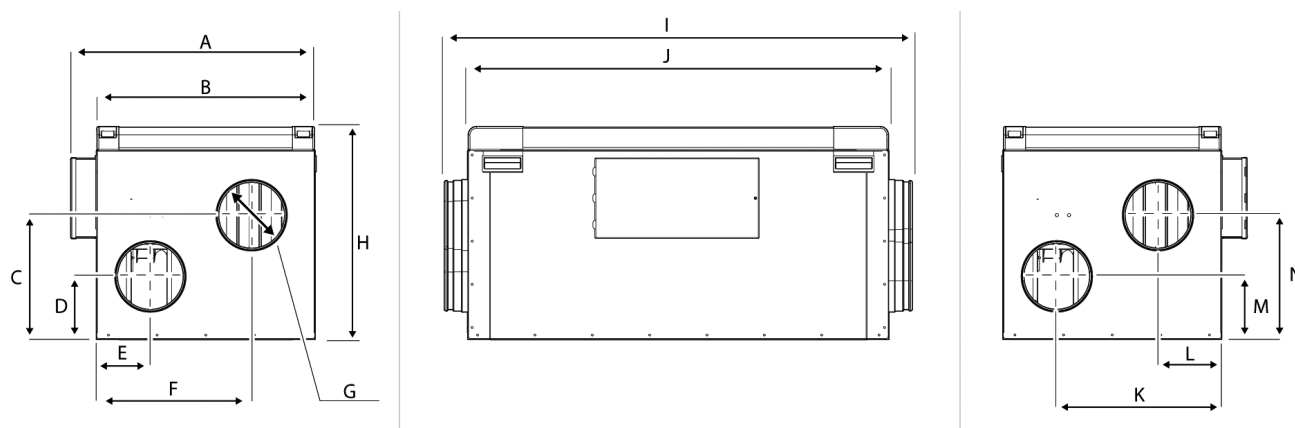

HERU S

	HERU 100 S EC	HERU 160 S EC	HERU 200 S EC	HERU 300 S EC
Total power (W)	1420	2020	2620	2890
Weight (kg)	59	77	101	105
Dimensions (mm)				
A	562	631	740	740
B	507	574	683	683
C	285	346	497	497
D	145	176	199	199
E	124	152	182	182
F	357	405	494	494
G	Ø 160 (4x)	Ø 200 (4x)	Ø 250 (4x)	Ø 250 (4x)
H	488	570	679	679
I	1075	1236	1352	1352
J	969	1131	1250	1250
K	379	418	498	498
L	146	165	186	186
M	145	176	199	199
N	285	346	497	497

For further technical data, see <https://www.ostberg.com>.

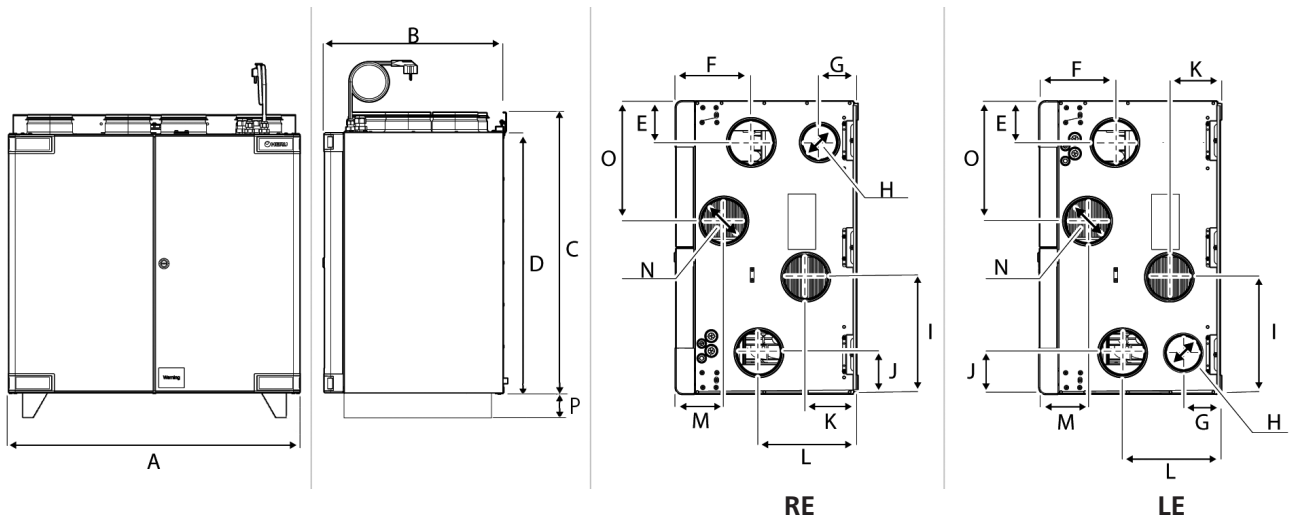

HERU T

	HERU 100 T EC	HERU 160 T EC	HERU 200 T EC	HERU 300 T EC
Total power (W)	1410	2020	2620	2880
Weight (kg)	66	95	136	140
Dimensions (mm)				
A	796	942	1124	1124
B	492	559	682	682
C	759	919	1135	1135
D	705	865	1082	1082
E	113	132	177	177
F	204	249	255	255
G	101	113	–	–
H	Ø 100 (1x)	Ø125 (1x)	–	–
I	318	370	442	442
J	112	130	174	174
K	138	138	474	474
L	265	310	250	250
M	130	149	479	479
N	Ø 125 (4x)	Ø 160 (4x)	Ø 250 (4x)	Ø 250 (4x)
O	326	372	446	446
P	–	–	100	100

For further technical data, see <https://www.ostberg.com>.

6 Connections main board

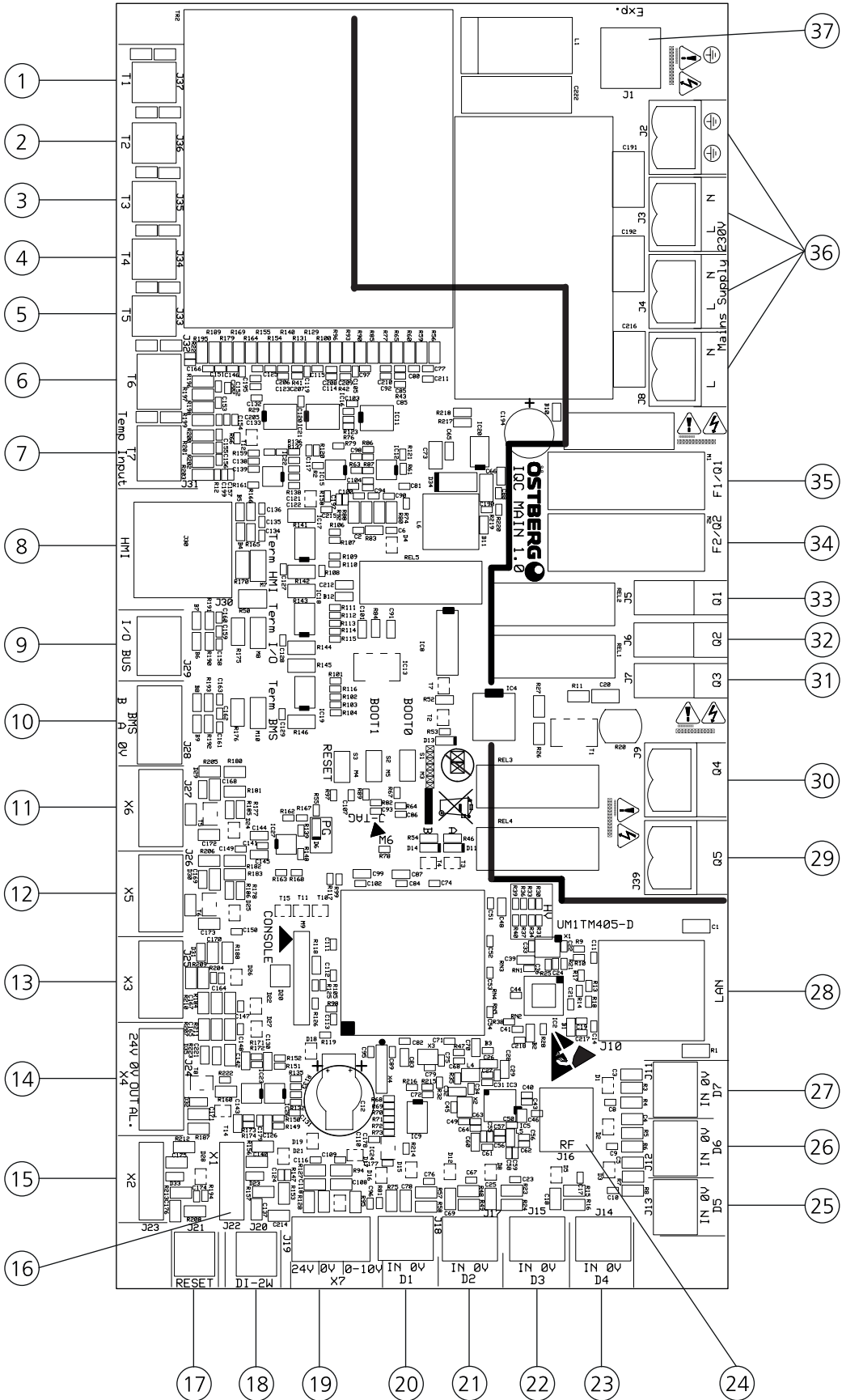

Pos.	PCB label	Description
1	T1	Internal temperature sensor
2	T2	Internal temperature sensor
3	T3	Internal temperature sensor
4	T4	Internal temperature sensor
5	T5	Freeze protection sensor
6	T6	Supply duct sensor (GT7)
7	T7	Room sensor (GT8)
8	HMI	Display port RJ45 (black)
9	I/O Bus	I/O Bus
10	BMS	RS 485 Modbus (slave)
11	X6	Preheater control output
12	X5	Afterheater control output
13	X3	Recovery control output
14	X4	Heating coil Ctrl Output (Analog out 0-10V / 24VAC 1,5VA)
15	X2	Fan 2 control output
16	X1	Fan 1 control output
17	Reset	External Reset
18	DI-2W	Rotor sensor (HALL)
19	X7	RH/CO2/VOC (Analog input 0-10V / 24VAC 1,3VA)
20	D1	Fire alarm (Digital input (floating))
21	D2	Boost (Digital input (floating))
22	D3	Overpressure (Digital input (floating))
23	D4	Extended Operation (Digital input (floating))
24	RF	SMA antenna output
25	D5	Away (Digital input (floating))
26	D6	Filter alarm (Digital input (floating))
27	D7	Electric heater Interlock (Digital input (floating))
28	LAN	10/100 Mbit Ethernet RJ-45
29	Q5	Floating output for pump heating
30	Q4	Damper (Digital relay output (NO))
31	Q3	Triac (Digital relay output (NO))
32	Q2	Fan 2 Power (Digital relay output (NO))
33	Q1	Fan 1 Power (Digital relay output (NO))
34	F2/Q2	Glass fuse T2.5A 5x20 L250V Fan 2
35	F1/Q1	Glass fuse T2.5A 5x20 L250V Fan 1
36	L/N	Main supply 230V
	L/N	Main supply 230V
	L/N	Main supply 230V
	PE	Main supply 230V
37	Exp.	Power to Expansion board

7 Control diagram

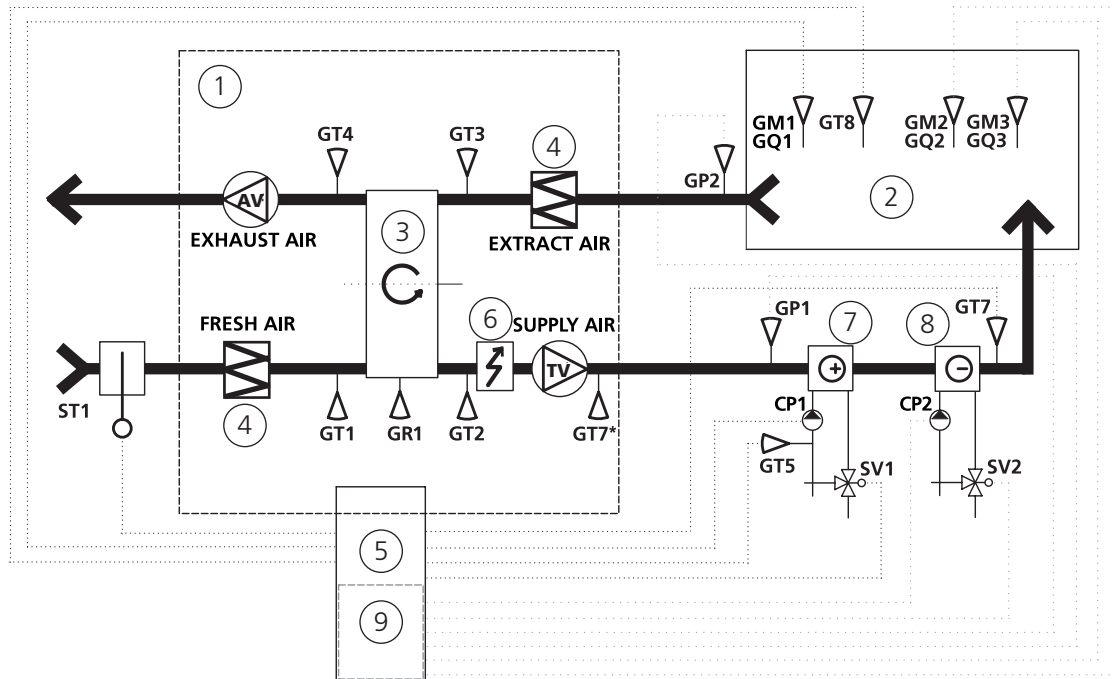

- 1 HERU unit
- 2 Room
- 3 Rotating heat exchanger
- 4 Filter
- 5 Control central containing relay board
- 6 Electric heater
- 7 Heating coil
- 8 Cooling coil
- 9 Electric expansion board

NOTE!

GT7* Temperature sensor location for HERU T.

GT7 Temperature sensor location for HERU S and when HERU T has a heating / cooling coil mounted after the unit.

Appendix 1 Commissioning Protocol HERU S /T

This commissioning protocol aims to ensure a correct installation of the product. The checklist helps a service technician / installer to carry out important checks, but is also used as a basis for handing over the completed installation to the end user.

Signing this document means that the recipient acknowledges the installation as completed.

Check a box after each action is performed.

- The service area is secured according to the design in the operating instructions **(Chapter: Preparation & placement)**. There must be sufficient space to service and replace parts in the unit.
- Installation and function check of GT7 (temperature sensor for the supply air duct) is carried out according to the operating instructions, applies to HERU-S models **(Chapter: Mount the temperature sensor GT7)**.
- Installation of antenna is performed according to the instructions for use, it shall not be mounted against a metallic surface. **(Chapter: Mount the antenna)**.
- Insulation of airducts has been carried out along its entire length, according to industry standards. **(Chapter: Duct insulation)**.
- In homes with a fireplace and / or separate kitchen fan, the function with overpressure is informed to the end user. **See the manual "Operation & maintenance - Overpressure"**.
- In homes with a cooker hood, the function with overpressure is informed to the end user. See the manual **"Operation & maintenance - Overpressure"**.
- The latest software for the product is installed.
- The fan regulation values in the table below are filled in and the user / customer has received information about its significance.
- For the warranty to apply - state that filter replacement and cleaning of the unit must take place at least once a year.

Fan regulation

Flow direction: Standard Opposite

Standard fan speed:

Exhaust air: _____% Reference: _____ Pa

Supply air _____% Reference: _____ Pa

Minimun fan speed (away mode): 

Exhaust air: _____% Reference: _____ Pa

Supply air _____% Reference: _____ Pa

Max fan speed (boost): 

Exhaust air: _____% Reference: _____ Pa

Supply air _____% Reference: _____ Pa

Signing and handing over installation to user / customer:

Product serial number (S/N): _____

Article number (801XXXX): _____

Responsible installer: _____

Installing company: _____

Place and date: _____

User / Customer: _____

Installation address: _____

Place and date: _____

There are sheets for further notes after the protocol.

Appendix 2 IQ Control App – Setup Wizard

The Setup Wizard is a easy setup tool for your HERU air handling unit. Follow the steps.

You find it under: Settings > Service > code 1991 > Setup Wizard.

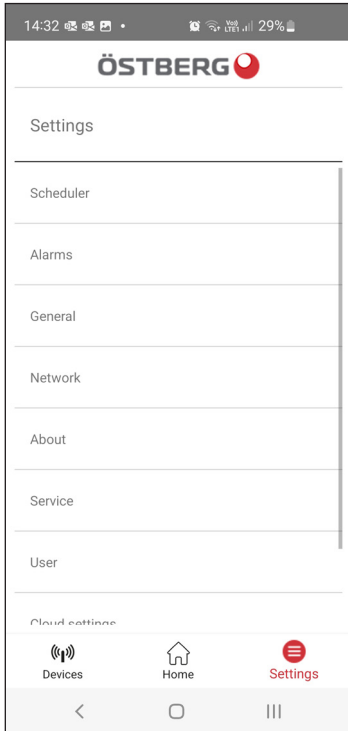

Choose Settings

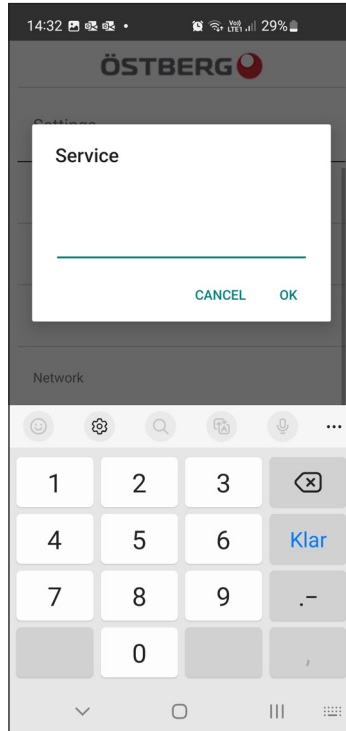

Choose Service

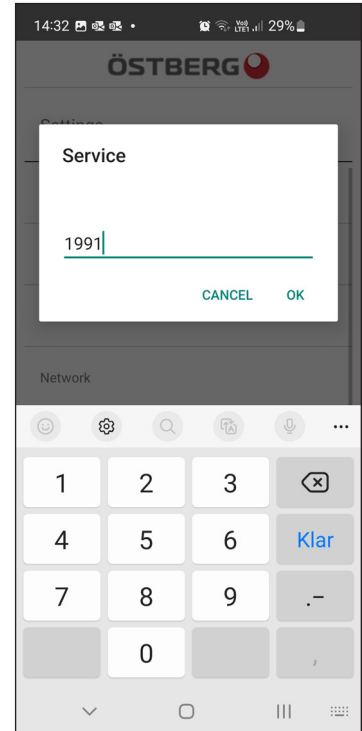

Write 1991

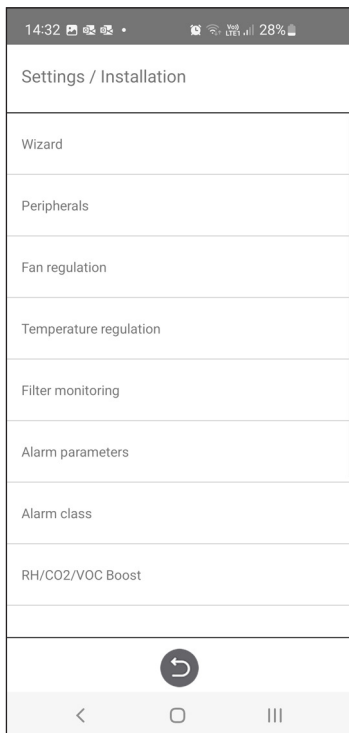

Choose Setup Wizard

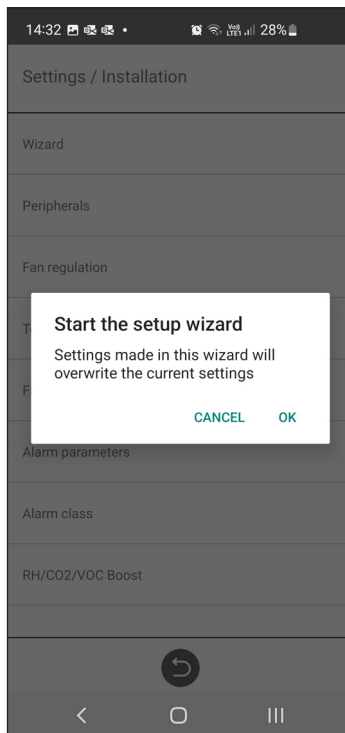

Setup Wizard start

1.1 Step 1 – RH/CO2/VOC Boost

Sensor type

Select the type of sensor and set the limit value for when fan compensation will activate.

If the limit value is exceeded, the supply and exhaust air flow will be increased steplessly.

When using more than one sensor, the value that is greatest is prioritized.

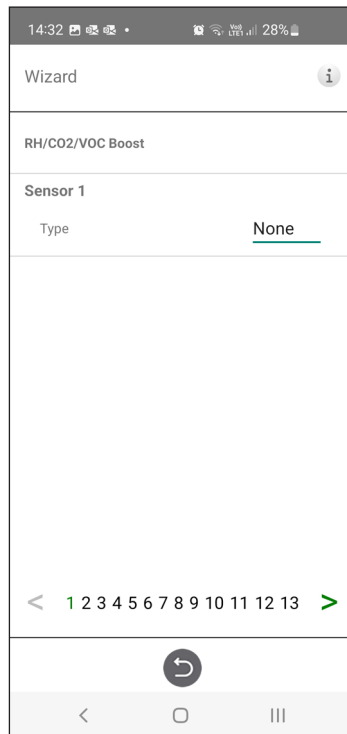

Setup Wizard –1 – RH/CO2/VOC Boost

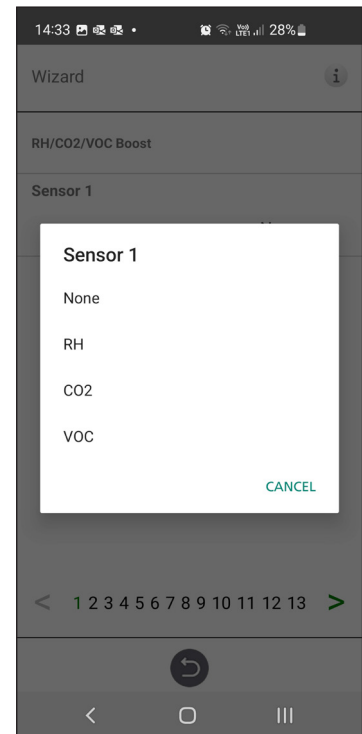

Setup Wizard –1 – RH/CO2/VOC Boost – choices

1.2 Step 2 – Heating and cooling

After Heater

Selection of which type of after heater that is installed. For electric heater, after-cooling function can also be set. For water, freeze protection parameters can be set:

- Hold temperature: When the plant is switched off, the water coil is kept warm so that the return water temperature is the same as the holding temperature set point.
- Limit B: Temperature limit value where heat valve is forced to full open.
- Limit A: Temperature limit where also the plant is stopped if it is in operation.

Pre-heater

Selection of which type of pre heater that is installed. Temperature set point is set to when pre heater is to start support heat the cold fresh air.

The pre-heater is controlled against the temperature at the outdoor air filter and is activated when the temperature in the outdoor air falls below the set point.

Cooling

Selection of which type of cooling device that is installed.

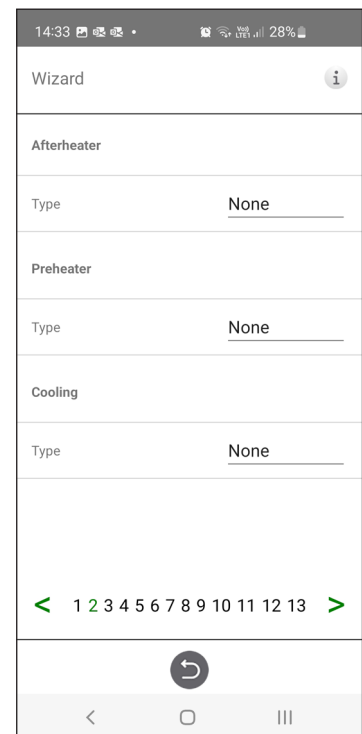

Setup Wizard – 2 – After heater

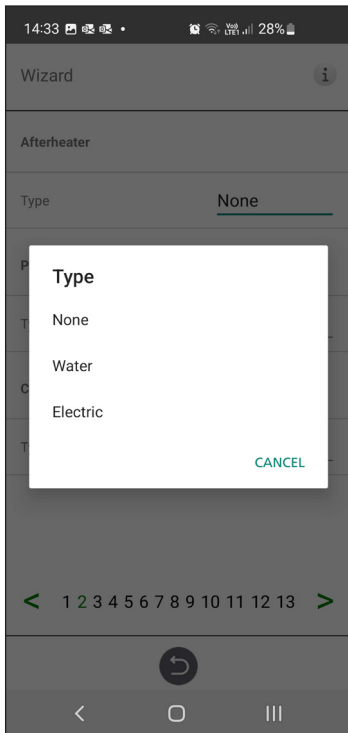

Setup Wizard – 2 – After heater – choices

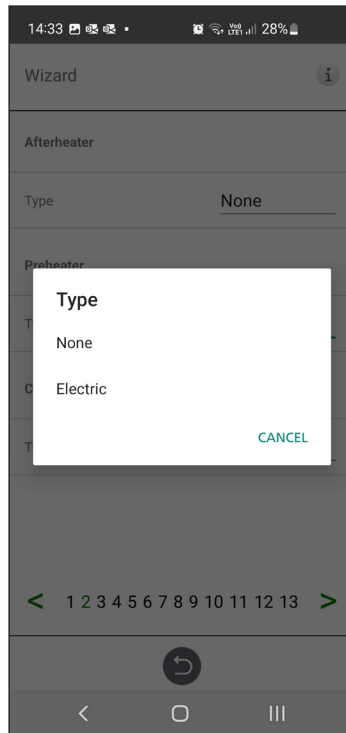

Setup Wizard – 2 – Pre heater– choices

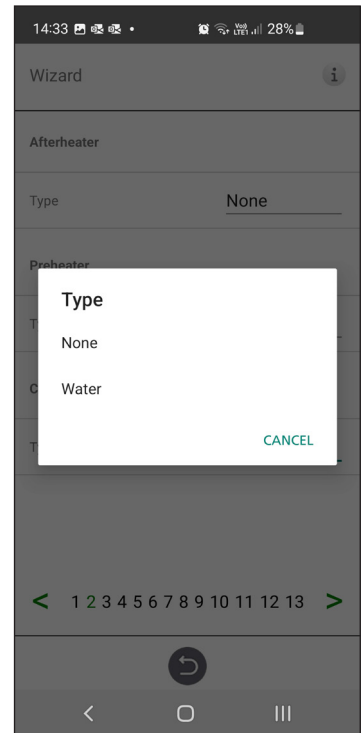

Setup Wizard – 2 – Cooling – choices

1.3 Step 3 – Temp regulation

Regulation Type

- Supply compare the temperature set point against the temperature in the supply air.
- Exhaust air compare the set point against the temperature in the extract air and regulates the temperature in the supply air between the set Min/Max limits.
- Room compare the set point against temperature from the room sensor and regulates the temperature in the supply air between set Min/Max limits.

Exhaust S/W and Room S/W enable automatic changeover of control type to supply air regulation in wintertime.

Changeover can be made on temperature criterion, date or via external input.

When Exhaust S/W or Room S/W is selected, a temperature offset factor can be set. This factor only affects supply air regulation in winter.

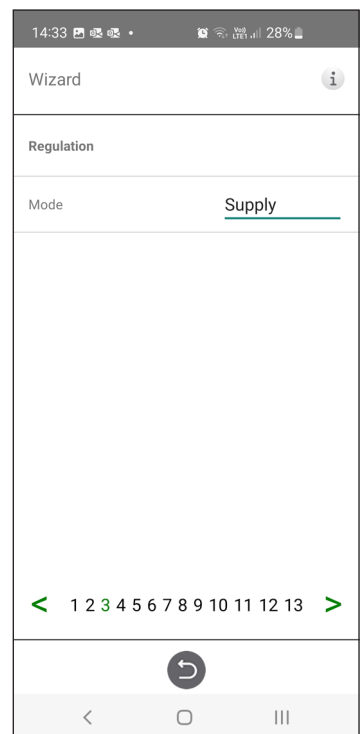

Setup Wizard – 3 – Temp regulation / Supply

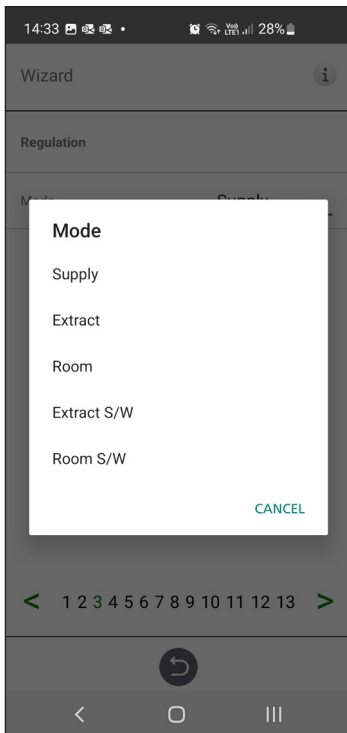

Setup Wizard – 3 – Temp regulation – choices

1.4 Step 4 – Temp set point & Supply temp low

Set point Max limit:

Set a maximum limit on the temperature set point setting.

Extra economy temperature set point can be activated, which allows for two temperature set points in the scheduler.

Supply air temperature Low:

- **Limit A:**
Temperature limit when alarms for low supply air temperature will be given.
- **Limit B:**
At which temperature limit the fan reduction will be activated.
- **Fan reduction:**
Reduction of supply air fan. Min 10%, Max % diff. between Max and Min speed.

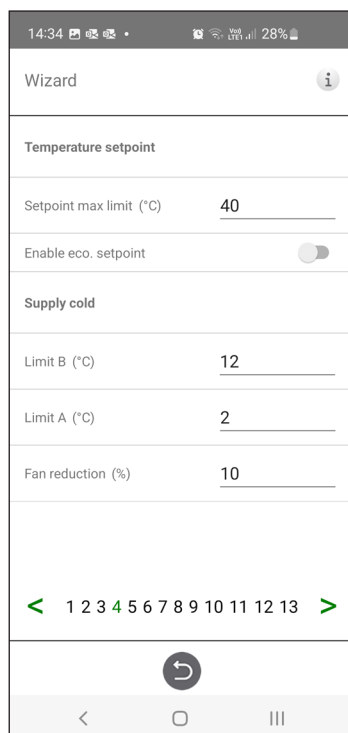

Setup Wizard – 4 – Temp set point

1.5 Step 5 – Switches

External inputs – Contact function:

Choice of contact function from external equipment.

NO: Normally open,
NC: Normally closed.

- Fire alarm:
- Fire mode: Function of fans in case of fire alarm.
- Forced speed: If fan is forced into operation, the % output signal will be used.

Automatic reset allows the unit to return to normal operation automatically when the external fire alarm is reset.

Emergency Stop / Service switch:

Possibility to use Emergency Stop / Service switch via input D6. If Expansion card is activated, the function is activated via input DI9.

External inputs - Signal type:

Choice of signal type from external equipment.

- "Pulse" is used for instant contact function.
- "Switch" is used for sustained contact function.

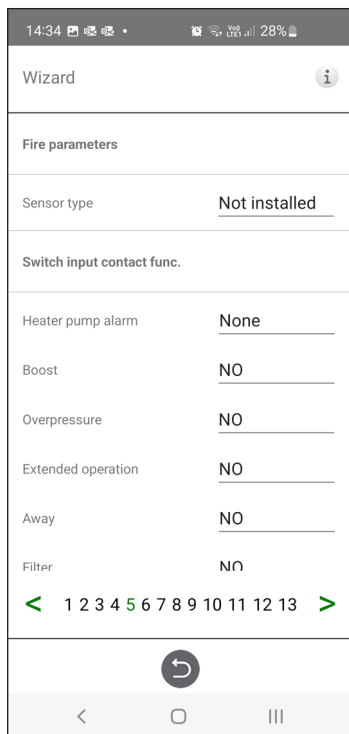

Setup Wizard – 5 – Switches

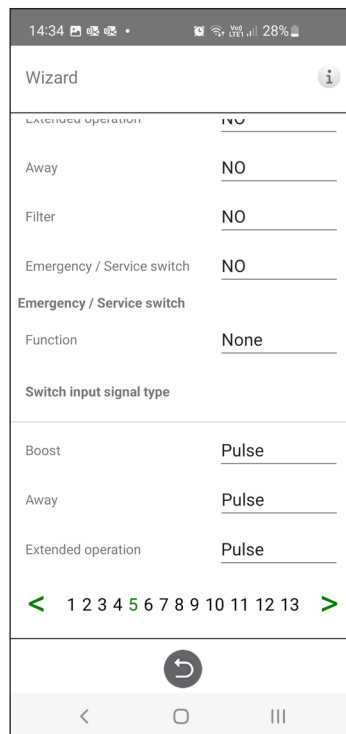

Setup Wizard – 5 – Switches

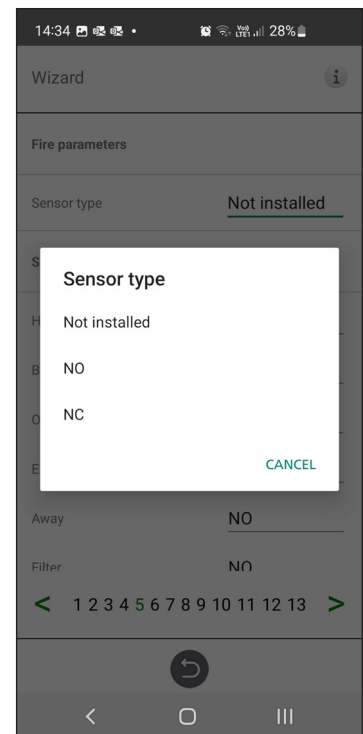

Setup Wizard – 5 – Switches – sensor type choice

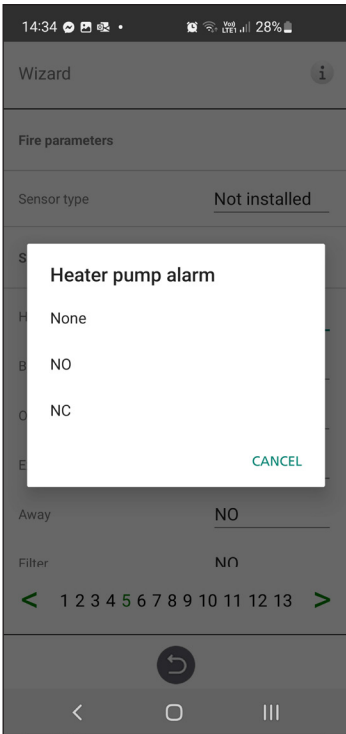

Setup Wizard – 5 – Switches – heater pump alarm choice

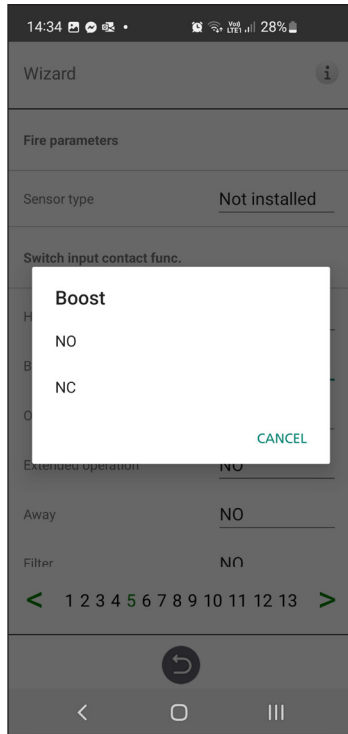

Setup Wizard – 5 – Switches – boost choice

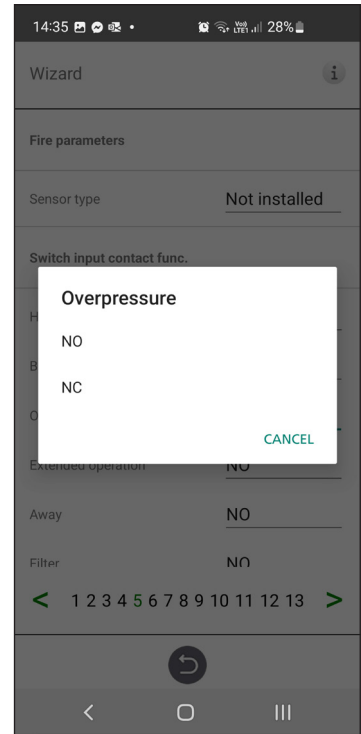

Setup Wizard – 5 – Switches – overpressure choice

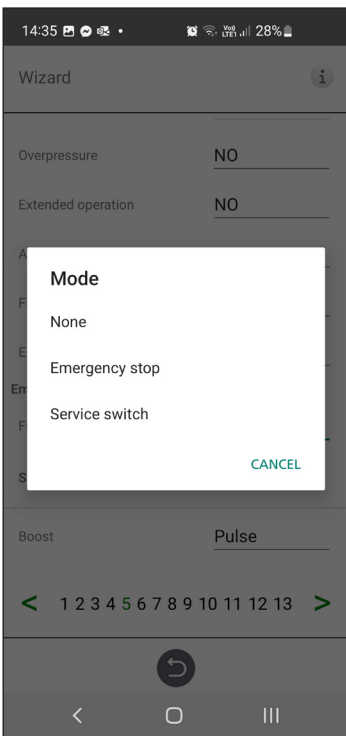

Setup Wizard – 5 – Switches – mode choice

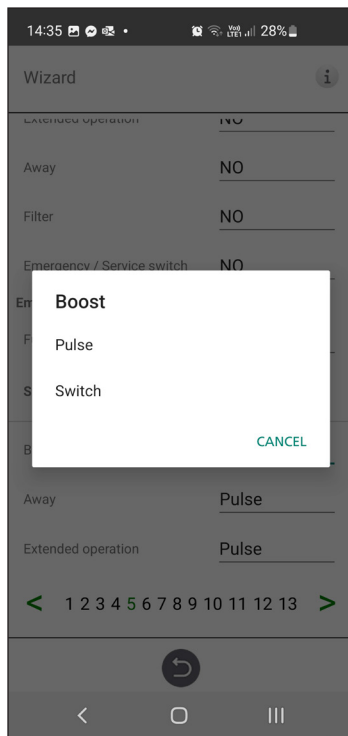

Setup Wizard – 5 – Switches – Boost choice

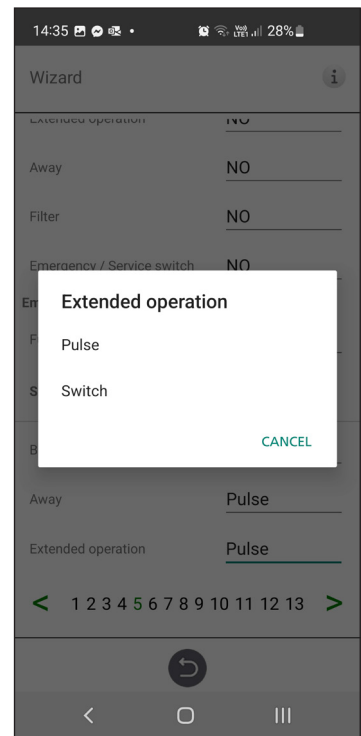

Setup Wizard – 5 – Switches – Ext. Operation choice

1.6 Step 6 – Alarm class

Settings of which alarm class that respective alarm should have.

Two levels can be selected:

- A-alarm: A critical alarm that will stop the ventilation unit.
- B-alarm: A non-critical alarm that keeps the ventilation unit in operation.

Alarm outputs:

- A-relay state: Contact function during normal operation.
- B-relay state: Contact function during normal operation.
- Run-relay state: Contact function during normal operation.

Alarm relay alerts:

Which alarms that will affect alarm output. Depending on the alarm class, the A-relay or the B-relay is affected.

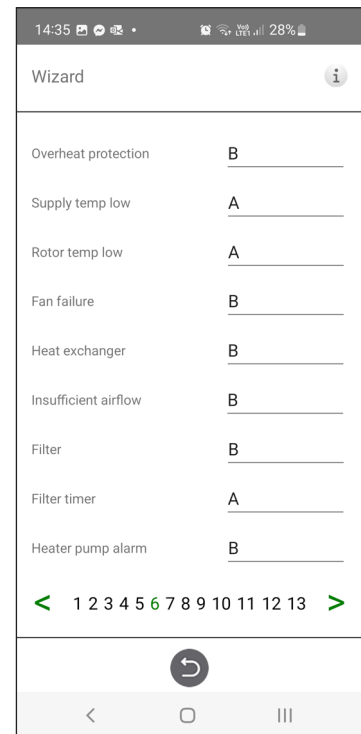

Setup Wizard – 6 – Alarm class

1.7 Step 7 – Filter measurement

Filter Measurement:

Type of filter control.

- Period: Selected by default. Gives an alarm when the service period has expired. Reset starts new service period.
- Diff. switch: Scheduled filter measurement at selected day & time (requires accessories).
- Diff. sensor: Scheduled filter measurement at selected day & time. Compare measured value against set final pressure drop (requires accessories).
- Speed increase: In CPC control of fans, the output signal of the fans can be used as a reference when measuring filter clogging. The limit value for filter alarms is the saved reference value of the fans increased by the set value for speed increase. Speed increase means keeping a constant pressure in the duct by increasing the fans' output signal to compensate for clogged filters (requires accessories).

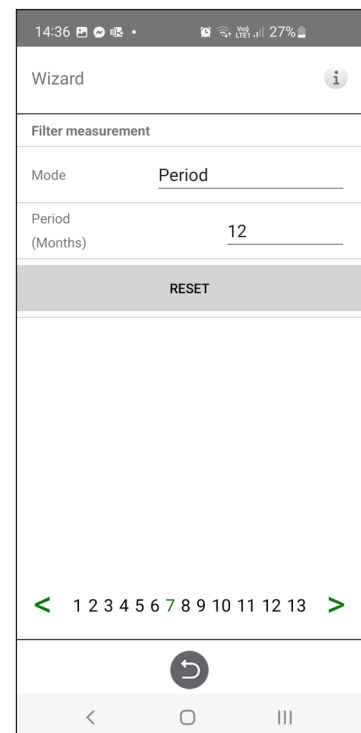

Setup Wizard – 7 – Filter measurement – Period

1.8 Step 8 – Dampers

Damper:

Opening time setting for dampers. Acts as start-up delay of the extract air fan to allow time for dampers to open.

For opening times, see separate data sheet for damper motor.

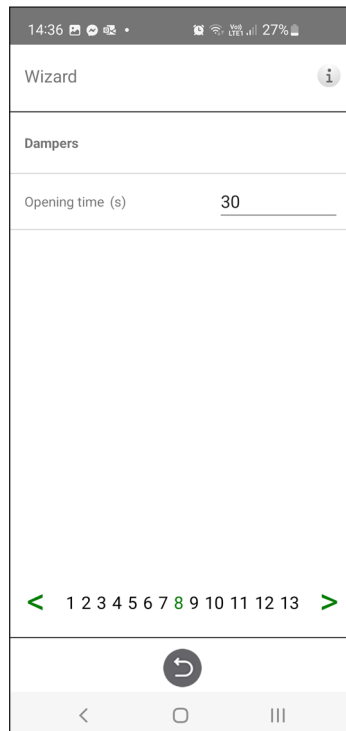

Setup Wizard – 8 – Dampers

1.9 Step 9 – Flow and regulation

Flow direction:

Can be set Standard or Opposite.

The "Opposite" setting is only used on ventilation units that have a design that allows the flow direction to be changed. See manual for more details.

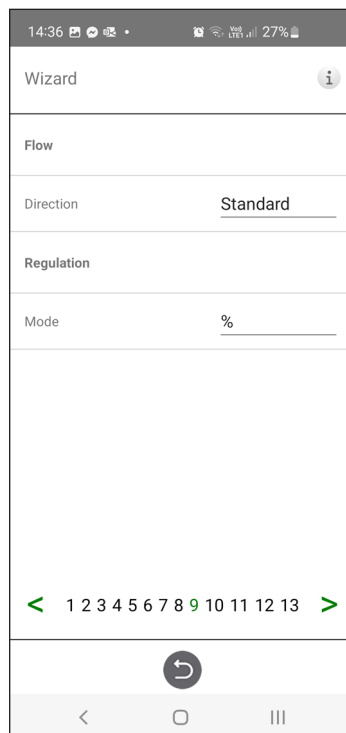

Setup Wizard – 9 – Flow and regulation

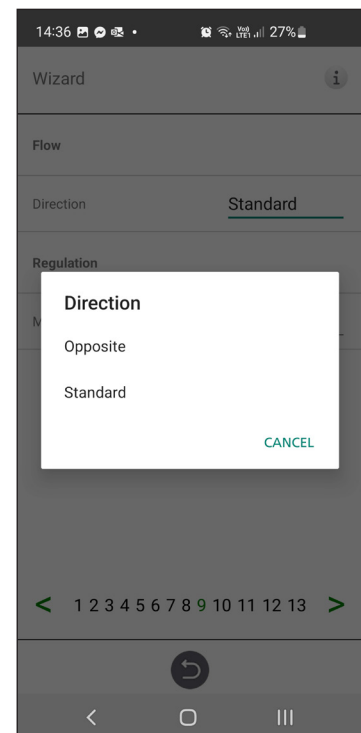

Setup Wizard – 9 – Flow and regulation – direction

1.10 Step 10 – Standard fan speed

Standard fan speed:

When entering the setup page, all program parameters that affect the flow of the fans are temporarily deactivated and the program is entering adjustment mode.

When leaving the setup page, the unit returns to normal operation.

The standard fan speed is the position where adjustment of the ventilation system shall be made. The supply and exhaust air flow can be adjusted individually.



Setup Wizard – 10 – Standard fan speed

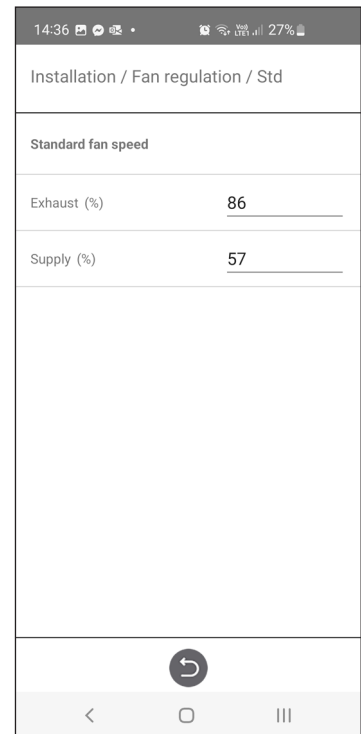

Setup Wizard – 10 – Std fan speed settings

1.11 Step 11 – Min fan speed

Min Speed:

When entering the setup page, all program parameters that affect the flow of the fans are temporarily deactivated and the program is entering adjustment mode. When leaving the setup page, the unit returns to normal operation.

The exhaust air flow can be adjusted. The supply air flow is calculated automatically based on the ratio in Standard fan speed. In the case of VAV regulation with static offset, the supply and exhaust air flow can be set individually.



Setup Wizard – 11 – Mix fan speed



Setup Wizard – 11 – Min fan speed settings

1.12 Step 12 – Max fan speed

Max Speed:

When entering the setup page, all program parameters that affect the flow of the fans are temporarily deactivated and the program is entering adjustment mode. When leaving the setup page, the unit returns to normal operation.

The exhaust air flow can be adjusted. The supply air flow is calculated automatically based on the ratio in Standard fan speed. In the case of VAV regulation with static offset, the supply and exhaust air flow can be set individually.



Setup Wizard – 12 – Max fan speed

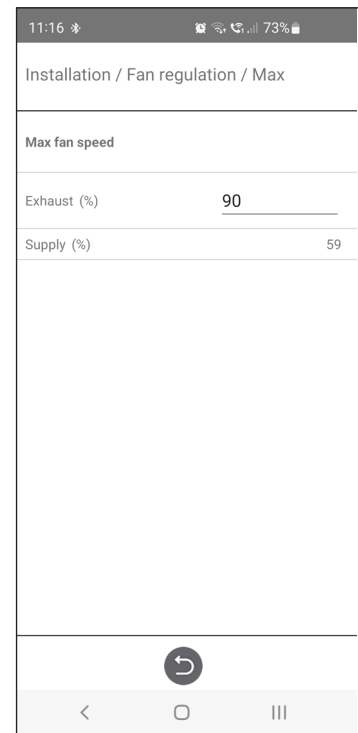

Setup Wizard – 12 – Max fan speed settings

1.13 Step 13 – Save settings

Press Yes to save all settings made in the wizard. Previously set values will be overwritten.

Press Cancel to discard all settings made in the wizard and return to the previous menu.

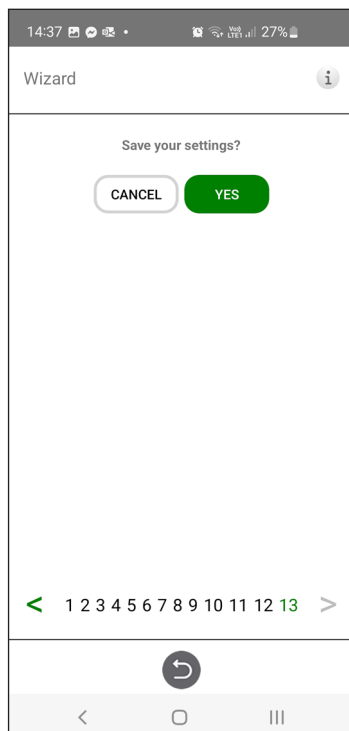

Setup Wizard – 13 – Save settings

energy
efficient
ventilation



H ÖSTBERG AB

Box 54, SE-774 22 Avesta, Sweden

Phone: +46 226 860 00

E-mail: info@ostberg.com

www.ostberg.com